

Spring  
Scheme of learning

**Year 4**

White Rose  
**MATHS**

#MathsEveryoneCan

Spring Block 1

# Multiplication and division B

## Small steps

Step 1

Factor pairs

Step 2

Use factor pairs

Step 3

Multiply by 10

Step 4

Multiply by 100

Step 5

Divide by 10

Step 6

Divide by 100

Step 7

Related facts – multiplication and division

Step 8

Informal written methods for multiplication



## Small steps

Step 9 Multiply a 2-digit number by a 1-digit number

Step 10 Multiply a 3-digit number by a 1-digit number

Step 11 Divide a 2-digit number by a 1-digit number (1)

Step 12 Divide a 2-digit number by a 1-digit number (2)

Step 13 Divide a 3-digit number by a 1-digit number

Step 14 Correspondence problems

Step 15 Efficient multiplication



# Factor pairs

## Notes and guidance

In this small step, children are introduced to factors for the first time. They learn that when they multiply two whole numbers to give a product, both the numbers that they multiplied together are factors of the product. For example,  $3 \times 5 = 15$ , so 3 and 5 are factors of 15. 3 and 5 are also referred to as a “factor pair” of 15

They then generalise this further to conclude that a factor of a number is a whole number that divides into it exactly.

Children create arrays using counters to develop their understanding of factor pairs. It is important for children to work systematically when finding the factor pairs of a number in order to ensure that they find all the factors. For example, when finding factor pairs of 12, begin with  $1 \times 12$ , then  $2 \times 6$ ,  $3 \times 4$ . At this stage, children should recognise that they have already used 4 in the previous calculation, therefore all factor pairs have been identified.

## Things to look out for

- Children may not work systematically, meaning that they could miss some factor pairs.
- Children may find it difficult to understand why not all factors come in pairs, for example  $4 \times 4 = 16$ , so this only gives 1 factor of 16, not 2

## Key questions

- How can you use arrays to help you find all the factors of a number?
- How do you know that you have found all the factors of \_\_\_\_\_?
- How do arrays help you to see when a number is not a factor of another number?
- Which number is a factor of every whole number?
- Do factors always come in pairs?
- Do whole numbers always have an even number of factors?

## Possible sentence stems

- \_\_\_\_\_ = \_\_\_\_\_  $\times$  \_\_\_\_\_, so \_\_\_\_\_ and \_\_\_\_\_ are a factor pair of \_\_\_\_\_
- \_\_\_\_\_ has \_\_\_\_\_ factors altogether.

## National Curriculum links

- Recognise and use factor pairs and commutativity in mental calculations

# Factor pairs

## Key learning

- Complete the factor pairs of 12 and the sentences.

  $1 \times \underline{\quad} = 12$

  $\underline{\quad} \times 6 = 12$

  $\underline{\quad} \times \underline{\quad} = 12$

12 has          factor pairs.

12 has          factors altogether.

- Use counters to create arrays and find the factor pairs for each number.

18

24

30

- Which of these numbers are factors of 20?

2    3    5    8    10    15

Use cubes or counters to show how you know.

- Here is a factor bug for 12

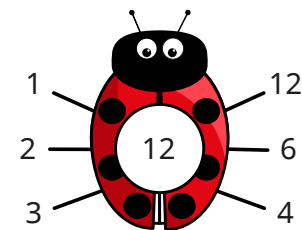

Complete the factor bug for 20

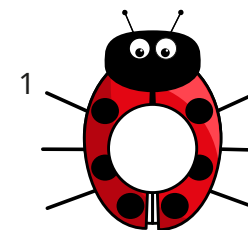

- Draw a factor bug for each number.

48

35

16

56

Which of the numbers has an odd number of factors?

Can you find another number with an odd number of factors?

- Find all the factor pairs of 60

# Factor pairs

## Reasoning and problem solving



The greater the number, the more factors it has.

Is Tommy correct?  
Use arrays to explain your answer.





No  
multiple possible answers, e.g.  
15 has 4 factors  
and 17 has 2 factors

Is the statement always true, sometimes true or never true?

An odd number has an odd number of factors.

Explain your answer to a partner.



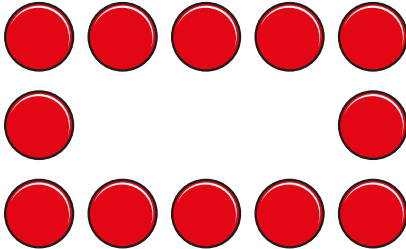

sometimes true

Alex has made an array using 12 counters.

5 and 3 are a factor pair of 12

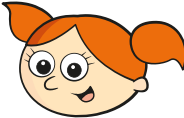

Do you agree with Alex?  
Explain your answer.



No

# Use factor pairs

## Notes and guidance

In this small step, children build on their knowledge of factor pairs from the previous step as they use them to write equivalent calculations. For example, as 3 and 4 are a factor pair of 12, this means that  $5 \times 12$  is equivalent to  $5 \times 3 \times 4$  or  $5 \times 4 \times 3$

Children explore equivalent calculations using different factors pairs, and then practise calculating with them to identify which factor pair produces the easiest calculation to complete mentally. The calculation that is deemed easiest will vary for different children, as they are likely to focus on using the times-tables they are most confident with.

## Things to look out for

- Children may need support finding the appropriate factor pairs that will enable them to solve the calculation mentally.
- Children may partition a number rather than finding a factor pair.

## Key questions

- How does knowing the factor pairs of 8 help you to find an equivalent calculation to  $7 \times 8$ ?
- For which number are you going to find the factor pairs?
- Which factor pair is the most helpful to solve the calculation?
- In what order are you going to multiply these numbers?
- Does it matter which factor pair you use?

## Possible sentence stems

- The factor pairs of \_\_\_\_\_ are \_\_\_\_\_
- $12 = \_\_\_\_\_ \times \_\_\_\_\_$ , so  $\_\_\_\_\_ \times 12 = \_\_\_\_\_ \times \_\_\_\_\_ \times \_\_\_\_\_$
- I can use the factor pairs of \_\_\_\_\_ to find an equivalent calculation because ...

## National Curriculum links

- Recognise and use factor pairs and commutativity in mental calculations



# Use factor pairs

## Key learning

- Rosie is working out  $7 \times 8$

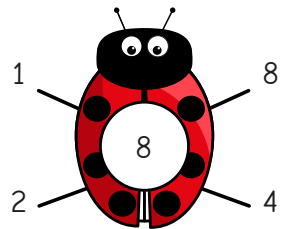

I can use a factor pair of 8 to help me.



$$7 \times 8 = 7 \times 4 \times 2 = 28 \times 2$$

double 28 is 56,  
so  $7 \times 8 = 56$

Use Rosie's method to work out the multiplications.

$6 \times 8$

$9 \times 8$

$12 \times 8$

- Use your knowledge of factor pairs to complete the calculations.

- ▶  $7 \times 6 = 7 \times \underline{\quad} \times 2 = \underline{\quad} \times 2 = \underline{\quad}$
- ▶  $5 \times 12 = 5 \times \underline{\quad} \times 2 = \underline{\quad} \times \underline{\quad} = \underline{\quad}$
- ▶  $9 \times 12 = 9 \times \underline{\quad} \times \underline{\quad} = \underline{\quad} \times \underline{\quad} = \underline{\quad}$
- ▶  $6 \times 9 = \underline{\quad} \times \underline{\quad} \times \underline{\quad} = \underline{\quad} \times \underline{\quad} = \underline{\quad}$

Could you have used different factor pairs?

Which factor pairs are the most helpful for each calculation?

- Mo is working out  $18 \times 3$

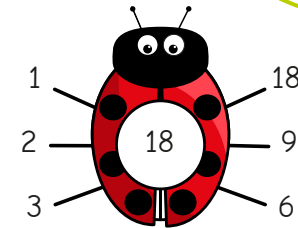

I can find the factor pairs of 18 to help me.



1 and 18  
2 and 9  
3 and 6

Mo chooses to use the factor pair 3 and 6



I can multiply in any order.

$$18 \times 3 = 3 \times 6 \times 3$$

$$= 3 \times 3 \times 6$$

$$= 9 \times 6 = 54$$

$$18 \times 3 = 54$$

Use Mo's method to work out the multiplications.

$18 \times 5$

$14 \times 3$

$16 \times 4$

- There are 15 children in Class 4

Each child gets 3 sweets.

How many sweets are there altogether?

# Use factor pairs

## Reasoning and problem solving

Is the statement true or false?

$$15 \times 4 = 10 \times 5 \times 4$$

Explain your answer.

False

Is the statement true or false?

$$16 \times 4 = 8 \times 8$$

Use factor pairs to explain your answer.

True

$$16 \times 4 = 8 \times 2 \times 4 \\ = 8 \times 8$$

Whitney wants to use factor pairs to work out  $13 \times 8$



The only factor pair of 13 is 1 and 13, so I cannot use factor pairs for this multiplication.

Is Whitney correct?

Explain your answer.

Work out the multiplication.

No

104

Tiny is working out  $17 \times 3$

I am going to use factor pairs to help me.

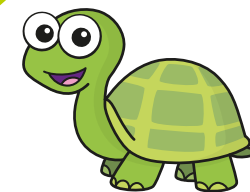

Will Tiny's method help?

Explain why.

No

# Multiply by 10

## Notes and guidance

In this small step, children explore multiplying by 10. They need to be able to visualise making a number 10 times the size and understand that “10 times the size” is the same as “multiply by 10”.

Children use their understanding that 1 ten is 10 times the size of 1 one and 1 hundred is 10 times the size of 1 ten to support them with this step. A place value chart is useful to show this. They recognise that when multiplying by 10 the digits move one place value column to the left and zero is needed as a placeholder in the now blank column. While children may notice a zero is always used as a placeholder when multiplying a whole number by 10, it is important that they do not develop the misconception that they just add a zero to multiply by 10, as this will cause confusion when multiplying decimals in later learning.

## Things to look out for

- Children may move only one digit and misplace the placeholder, for example  $45 \times 10 = 405$
- Children may not realise that calculations of the form  $10 \times \underline{\quad}$  and  $\underline{\quad} \times 10$  can be carried out in the same way.

## Key questions

- What do you notice when multiplying by 10?
- What is a placeholder? When do you use placeholders?
- What happens to the digits in a number when you multiply by 10?
- How can you use a place value chart to show multiplying  $\underline{\quad}$  by 10?
- What is  $\underline{\quad}$  multiplied by 10?
- What is 10 lots of  $\underline{\quad}$ ?

## Possible sentence stems

- $\underline{\quad} \times 10 = \underline{\quad}$
- $10 \times \underline{\quad} = \underline{\quad}$
- $\underline{\quad}$  is 10 times the size of  $\underline{\quad}$

## National Curriculum links

- Recall multiplication and division facts for multiplication tables up to  $12 \times 12$
- Multiply and divide whole numbers and those involving decimals by 10, 100 and 1,000 (Y5)

# Multiply by 10

## Key learning

- Use the base 10 to complete the sentences.



$3 \times 1 \text{ one} = \underline{\quad\quad} \text{ ones}$

$3 \times 1 = \underline{\quad\quad}$

What do you notice?

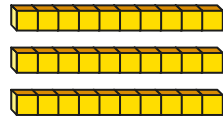

$3 \times 1 \text{ ten} = \underline{\quad\quad} \text{ tens}$

$3 \times 10 = \underline{\quad\quad}$

- Use base 10 to complete the number sentences.

$2 \times 1 = \underline{\quad\quad} \quad 1 \times 6 = \underline{\quad\quad} \quad 7 \times 1 = \underline{\quad\quad}$

$2 \times 10 = \underline{\quad\quad} \quad 10 \times 6 = \underline{\quad\quad} \quad 10 \times 7 = \underline{\quad\quad}$

- Mo represents  $21 \times 10$  using place value counters.

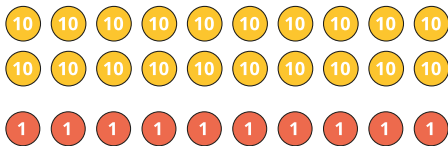

I need to exchange to find the answer.



What exchanges does Mo need to make?

What is  $21 \times 10$ ?

- Use place value counters to complete the multiplications.

$23 \times 10$

$16 \times 10$

$31 \times 10$

- Dexter uses a place value chart to work out  $32 \times 10$

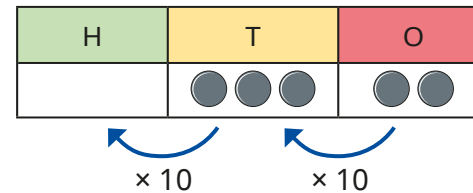

I can see that when I multiply by 10, all the counters move one place to the left on a place value chart.

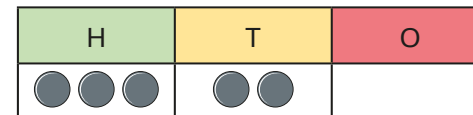

$32 \times 10 = 320$

What do you notice?

Use Dexter's method to work out the multiplications.

$82 \times 10$

$68 \times 10$

$43 \times 10$

# Multiply by 10

## Reasoning and problem solving

Aisha multiplies a whole number by 10

Her answer is between 440 and 540

What number could Aisha have multiplied by 10?

How many possibilities can you find?



any number between 45 and 53

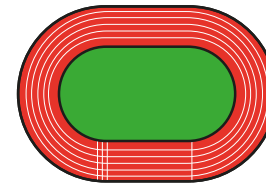

Filip runs 80 m.

Kim runs 10 times as far.

How far do they run altogether?

880 m

Is the statement always true, sometimes true or never true?

If you write a whole number in a place value chart and multiply it by 10, all the digits move one column to the left.



Talk about your answer with a partner.

always true

Max and Tiny have some money.

Tiny has 50p.

I have ten times as much money as Tiny.



£5

How much money does Max have?

# Multiply by 100

## Notes and guidance

Building on the previous step, children learn to multiply whole numbers by 100, understanding that this is the same as multiplying by 10 and then multiplying by 10 again. They need to be able to visualise making a number 100 times the size and understand that “100 times the size” is the same as “multiply by 100”.

Children use a place value chart, counters and base 10 to explore what happens to the values of the digits when multiplying by 100. Encourage children to recognise that when multiplying whole numbers by 100, the digits move two place value columns to the left and zeros are needed as placeholders in the now blank columns. As with multiplying by 10 in the previous step, it is important that they do not develop the misconception that they just add two zeros to multiply by 100, as this will cause confusion when multiplying decimals by 100

## Things to look out for

- Children may move only some of the digits and misplace the placeholder, for example  $45 \times 100 = 4,005$
- Children may need support to recognise that multiplying by 100 is the same as multiplying by 10 and multiplying by 10 again.

## Key questions

- What do you notice when multiplying by 100?
- How can you use multiplying by 10 to help you multiply by 100?
- What happens to the digits when you multiply by 100?
- How can you use a place value chart to show multiplying \_\_\_\_\_ by 100?
- What is \_\_\_\_\_ multiplied by 100?
- What is 100 lots of \_\_\_\_\_?

## Possible sentence stems

- \_\_\_\_\_  $\times$  100 = \_\_\_\_\_  $\times$  10  $\times$  10 = \_\_\_\_\_  $\times$  10 = \_\_\_\_\_
- \_\_\_\_\_  $\times$  100 = \_\_\_\_\_, so 100  $\times$  \_\_\_\_\_ = \_\_\_\_\_
- \_\_\_\_\_ is 100 times the size of \_\_\_\_\_

## National Curriculum links

- Recall multiplication and division facts for multiplication tables up to  $12 \times 12$
- Multiply and divide whole numbers and those involving decimals by 10, 100 and 1,000 (Y5)

# Multiply by 100

## Key learning

- Use the base 10 to complete the number sentences.

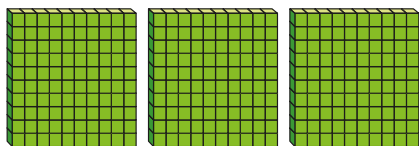

$3 \times 1 \text{ hundred} = \underline{\hspace{2cm}}$  hundreds

$3 \times 100 = \underline{\hspace{2cm}}$

- Complete the number sentences.

▶  $2 \times 100 = \underline{\hspace{2cm}}$

▶  $\underline{\hspace{2cm}} = 4 \times 100$

▶  $100 \times 6 = \underline{\hspace{2cm}}$

▶  $\underline{\hspace{2cm}} = 100 \times 7$

- There are 8 jars.

Each jar contains 100 drawing pins.

How many drawing pins are there altogether?



- Work out the multiplications.

▶  $7 \times 1$        $7 \times 10$        $70 \times 10$        $7 \times 100$

▶  $3 \times 1$        $3 \times 10$        $30 \times 10$        $3 \times 100$

▶  $8 \times 1$        $8 \times 10$        $80 \times 10$        $8 \times 100$

What do you notice?

- Dora uses a place value chart to work out  $23 \times 100$

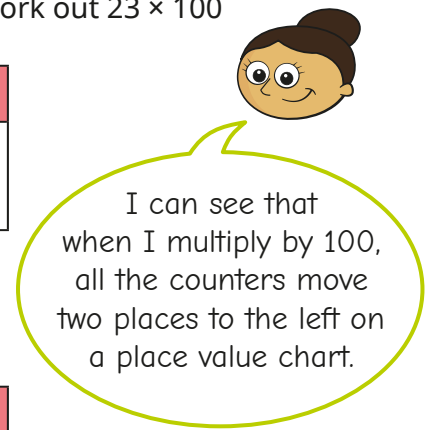
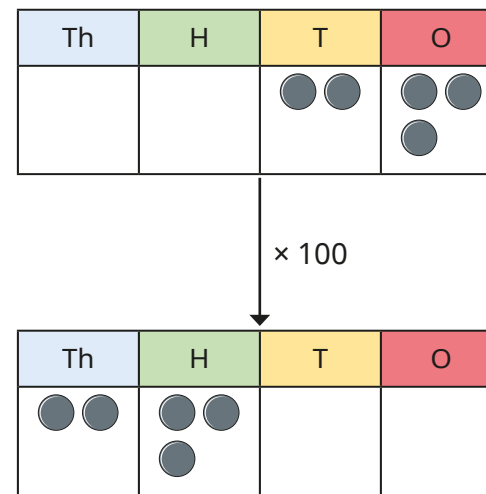

$23 \times 100 = 2,300$

Use Dora's method to work out the multiplications.

$41 \times 100$

$94 \times 100$

$83 \times 100$

- Write  $<$ ,  $>$  or  $=$  to compare the multiplications.

$75 \times 100$  ○  $75 \times 10$

$460 \times 10$  ○  $100 \times 47$

$39 \times 100$  ○  $39 \times 10 \times 10$

$10 \times 420$  ○  $42 \times 100$

# Multiply by 100

## Reasoning and problem solving

Which function machine does **not** multiply by 100?

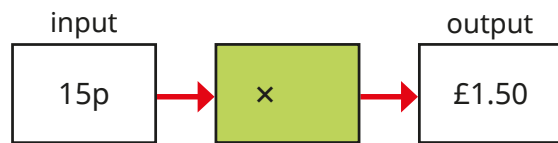
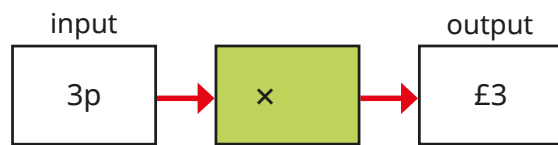

$15p \times 10 = £1.50$

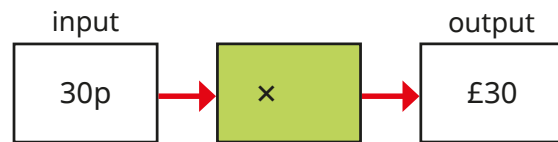

Explain your answer.



A designer draws a plan of a room.

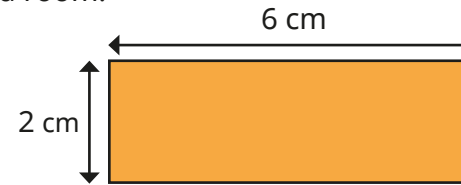

length: 6 m  
width: 2 m

The length and width of the actual room are 100 times the size of the plan.

What is the length and width of the room?

Give your answer in metres.

Huan has 4 balloons.

Brett has 10 times as many balloons as Huan.

Nijah has 100 times as many balloons as Huan.

How many balloons do they have altogether?

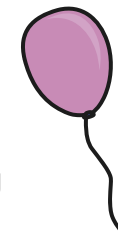

444 balloons



# Divide by 10

## Notes and guidance

In this small step, children divide whole numbers by 10, with questions that only have whole number answers. They need to be able to visualise making a number one-tenth the size and understand that “one-tenth the size” is the same as “dividing by 10”.

Children use concrete resources and a place value chart to see the link between dividing by 10 and the position of the digits of a number before and after the calculation. They recognise that when dividing by 10, the digits move one place value column to the right. They begin to understand that multiplying by 10 and dividing by 10 are the inverse of each other.

Children may notice that in all the examples they see, they need to “remove the zero” to find the answer. Ensure that they do not generalise this too far and use it as their method, as this will cause issues in later learning when looking at decimals.

## Things to look out for

- Children may incorrectly conclude that to divide by 10, they always just remove a zero from the number.
- Children may confuse multiplying and dividing by 10, and move the digits in the wrong direction in a place value chart.

## Key questions

- What do you notice when dividing by 10?
- Why does this happen?
- What happens to the digits when you divide by 10?
- How can you use a place value chart to show dividing \_\_\_\_\_ by 10?
- What is \_\_\_\_\_ divided by 10?
- What number is one-tenth the size of \_\_\_\_\_?

## Possible sentence stems

- \_\_\_\_\_  $\div$  10 = \_\_\_\_\_
- \_\_\_\_\_ = \_\_\_\_\_  $\div$  10
- \_\_\_\_\_ is one-tenth the size of \_\_\_\_\_

## National Curriculum links

- Recall multiplication and division facts for multiplication tables up to  $12 \times 12$
- Multiply and divide whole numbers and those involving decimals by 10, 100 and 1,000 (Y5)

# Divide by 10

## Key learning

- Complete the calculation shown by the array.

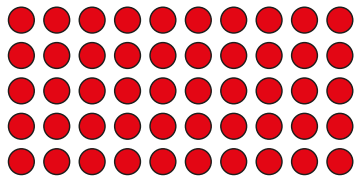

50 = \_\_\_\_\_ groups of 10

50 ÷ 10 = \_\_\_\_\_

- Draw arrays to help you complete the divisions.

▶ 30 ÷ 10 = \_\_\_\_\_      ▶ \_\_\_\_\_ = 10 ÷ 10

▶ 40 ÷ 10 = \_\_\_\_\_      ▶ \_\_\_\_\_ = 20 ÷ 10

- Sam uses base 10 to divide 140 by 10

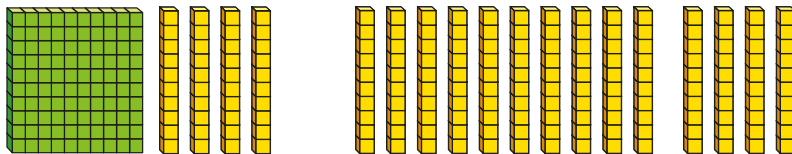

140 = 1 hundred and 4 tens  
1 hundred = 10 tens  
There are 14 groups of 10  
140 ÷ 10 = 14

Use Sam's method to complete the divisions.

▶ 120 ÷ 10 = \_\_\_\_\_      ▶ \_\_\_\_\_ = 230 ÷ 10

▶ 170 ÷ 10 = \_\_\_\_\_      ▶ \_\_\_\_\_ = 260 ÷ 10

- Jack uses a place value chart to work out 340 ÷ 10

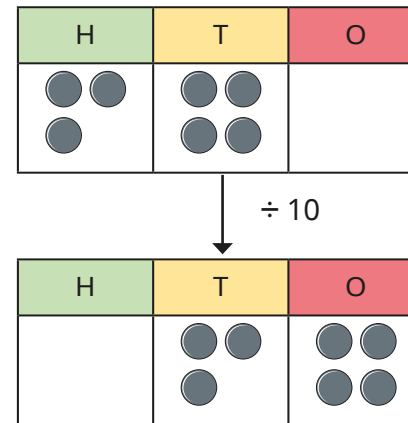

I can see that when I divide by 10, all the counters move one place to the right on a place value chart.

340 ÷ 10 = 34

Use Jack's method to work out the divisions.

480 ÷ 10

620 ÷ 10

930 ÷ 10

- Ten friends share some money equally from a money box.
  - ▶ How much would they each have if the box contained:
    - twenty £1 coins
    - £120?
  - ▶ After emptying the box and sharing the contents equally, each friend has 90p.

How much money was in the box?

## Divide by 10

## Reasoning and problem solving

Scott, Tom, Esther and Dani are in a race.

Here are the numbers on their vests.

350	35
3,500	53

Use the clues to match each vest number to a child.

- Scott's number is one-tenth the size of Tom's.
- Nobody has a number that is 10 times the size of Esther's.
- Dani's number is one-tenth the size of Scott's.

Scott: 350  
Tom: 3,500  
Esther: 53  
Dani: 35

Mr Rose is buying furniture.

To make sure it will fit in the room, he decides to draw a plan.

The actual size of everything is 10 times the size that it is on the plan.

He makes a table to show the measurements.

Item	Actual size	Plan size
Bed length	200 cm	2,000 cm
Desk length	120 cm	12 cm
Wardrobe height	1,850 mm	185 mm

Are Mr Rose's plan measurements correct?

Explain your answers.

The length of the room is 240 cm.

How long will it be on the drawing?

bed: incorrect  
desk: correct  
wardrobe: correct

24 cm

# Divide by 100

## Notes and guidance

In this small step, children build on their understanding of dividing by 10 and notice the link between dividing by 10 and dividing by 100. They need to be able to visualise making a number one-hundredth the size and understand that “one-hundredth the size” is the same as “dividing by 100”.

Children use concrete resources and a place value chart to see the link between dividing by 100 and the position of the digits before and after the calculation. They realise that when dividing by 100, the digits move two place value columns to the right. They begin to understand that multiplying by 100 and dividing by 100 are the inverses of each other.

Money is a good real-life context for this small step, as exchanging, for example, pounds for pence can be used for the concrete stage.

## Things to look out for

- Children may need support in recognising that one-hundredth the size is the same as dividing by 100
- Children may divide by 10 instead of 100
- Children may confuse multiplying and dividing by 100, and move the digits in the wrong direction.

## Key questions

- What happens when you divide a number by 10 and then divide the answer by 10 again? How does the final answer compare to the original number?
- How can you use dividing by 10 to help you divide by 100?
- What happens to the digits in a number when you divide by 100?
- How can you use a place value chart to show dividing \_\_\_\_\_ by 100?
- What is \_\_\_\_\_ divided by 100?
- What number is one-hundredth the size of \_\_\_\_\_?

## Possible sentence stems

- \_\_\_\_\_  $\div$  100 = \_\_\_\_\_  $\div$  10  $\div$  10 = \_\_\_\_\_  $\div$  10 = \_\_\_\_\_
- \_\_\_\_\_  $\div$  100 = \_\_\_\_\_, so \_\_\_\_\_ = \_\_\_\_\_  $\div$  100
- \_\_\_\_\_ is one-hundredth the size of \_\_\_\_\_

## National Curriculum links

- Recall multiplication and division facts for multiplication tables up to  $12 \times 12$
- Multiply and divide whole numbers and those involving decimals by 10, 100 and 1,000 (Y5)

# Divide by 100

## Key learning

- Use the ten frame and counters to complete the sentences.

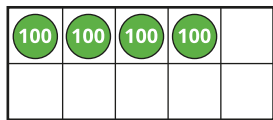

There are \_\_\_\_\_ groups of 100 in 400

$400 \div 100 = \underline{\hspace{2cm}}$

- Use counters to complete the divisions.

- ▶  $600 \div 100 = \underline{\hspace{2cm}}$
- ▶  $900 \div 100 = \underline{\hspace{2cm}}$
- ▶  $\underline{\hspace{2cm}} = 1,000 \div 100$
- ▶  $\underline{\hspace{2cm}} = 700 \div 100$

- Teddy uses base 10 to work out 1,200 divided by 100

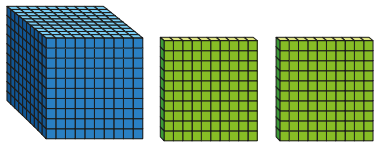

1,200 = 1 thousand and 2 hundreds  
 1 thousand = 10 hundreds  
 There are 12 groups of 100  
 $1,200 \div 100 = 12$

Use Teddy's method to complete the divisions.

- ▶  $3,000 \div 100 = \underline{\hspace{2cm}}$
- ▶  $4,500 \div 100 = \underline{\hspace{2cm}}$
- ▶  $\underline{\hspace{2cm}} = 5,100 \div 100$
- ▶  $2,300 \div 100 = \underline{\hspace{2cm}}$

- Amir uses a place value chart to work out  $3,400 \div 100$

Th	H	T	O
●●	●●●●		

$\div 100$

Th	H	T	O
		●●	●●●●



I can see that when I divide by 100, all the counters move two places to the right on a place value chart.

$3,400 \div 100 = 34$

Use Amir's method to work out the divisions.

$4,900 \div 100$	$5,300 \div 100$	$8,100 \div 100$
------------------	------------------	------------------

- Kim has collected 800 1p coins.  
 How much money has Kim collected altogether?  
 Give your answer in pounds.

# Divide by 100

## Reasoning and problem solving

Alex and Tommy are dividing numbers by 10 and 100

They both start with the same 4-digit number.

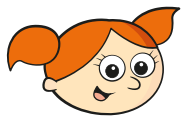

My answer has 8 ones and 2 tens.

Alex

My answer has 2 hundreds, 8 tens and 0 ones.



Tommy

What number did Alex and Tommy both start with?

Who divided by what?

2,800

Alex: 100

Tommy: 10

Use the digits 1 to 9 to complete the calculations.

$$170 \div 10 = \_ \_$$

$$\_20 \times 10 = 3,\_00$$

$$1,8\_0 \div 10 = 1\_6$$

$$\_9 \times 100 = 5,\_00$$

$$6\_ = 6,400 \div 100$$

$$170 \div 10 = 17$$

$$320 \times 10 = 3,200$$

$$1,860 \div 10 = 186$$

$$59 \times 100 = 5,900$$

$$64 = 6,400 \div 100$$

Without working out the answers, use  $<$ ,  $>$  or  $=$  to compare the calculations.

$$3,600 \div 10 \bigcirc 3,600 \div 100$$

$$2,700 \div 100 \bigcirc 270 \div 10$$

$>$

$=$

Explain your reasoning.

## Related facts – multiplication and division

### Notes and guidance

In this small step, children bring together the skills learnt so far in this block as they explore calculations related to known facts.

Children explore scaling facts by 10 and 100, for example using the fact that  $4 \times 7 = 28$  to derive  $4 \times 70 = 280$  and  $4 \times 700 = 2,800$ .

They then look at this relationship with division, for example using  $12 \div 3 = 4$  to derive  $120 \div 3 = 40$  and  $1,200 \div 3 = 400$ .

Care should be taken to ensure that children do not also think that  $12 \div 30 = 40$ . This is a good opportunity to remind children that multiplication is commutative, but division is not.

A range of representations are used to make the link between multiples of 1, 10 and 100 that will be familiar to children from previous steps in this block and in Year 3

### Things to look out for

- Children may derive incorrect division facts by using the rules that they have learnt about related multiplication facts.
- Children may try to find results by calculation rather than recognising the relationship between one fact and another.

### Key questions

- What is the same and what is different about the two calculations?
- How can you represent the calculation using place value counters?
- How does knowing that \_\_\_\_\_ is 10 times the size of \_\_\_\_\_ help you to complete the calculation?
- What calculation do you know that would help with this one?

### Possible sentence stems

- \_\_\_\_\_  $\times$  \_\_\_\_\_ ones is equal to \_\_\_\_\_ ones,  
so \_\_\_\_\_  $\times$  \_\_\_\_\_ tens is equal to \_\_\_\_\_ tens.
- \_\_\_\_\_  $\div$  \_\_\_\_\_ is equal to \_\_\_\_\_,  
so \_\_\_\_\_ tens  $\div$  \_\_\_\_\_ is equal to \_\_\_\_\_ tens.

### National Curriculum links

- Solve problems involving multiplying and adding, including using the distributive law to multiply 2-digit numbers by 1 digit, integer scaling problems and harder correspondence problems such as  $n$  objects are connected to  $m$  objects

# Related facts – multiplication and division

## Key learning

- Write two multiplication facts and two division facts represented by each array.

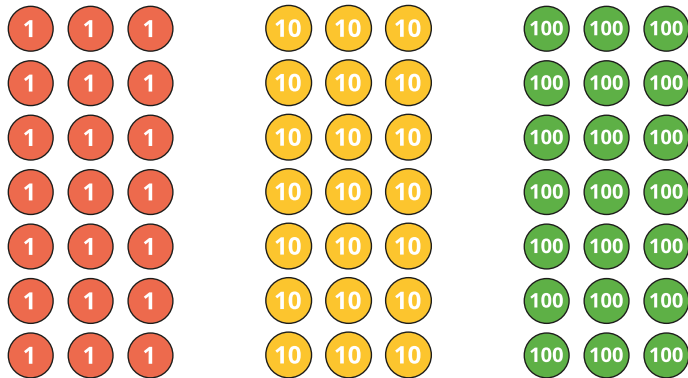

What is the same and what is different about the arrays?



I know that  
3 x 5 ones = 15 ones,  
so 3 x 5 tens = 15 tens.

$$3 \times 50 = 150$$

Use Max's method to complete the calculations.

▶  $3 \times 9 = \underline{\quad}$     ▶  $4 \times 8 = \underline{\quad}$     ▶  $\underline{\quad} = 5 \times 7$   
 $3 \times 900 = \underline{\quad}$      $4 \times \underline{\quad} = 320$      $3,500 = 5 \times \underline{\quad}$

- Mo is working out  $1,200 \div 3$



I know that  
12 ones  $\div$  3 is equal to 4 ones.  
So 12 hundreds  $\div$  3  
is equal to 4 hundreds.  
 $1,200 \div 3 = 400$

Use Mo's method to work out the divisions.

$$560 \div 7$$

$$480 \div 6$$

$$720 \div 12$$

$$5,600 \div 7$$

$$4,800 \div 6$$

$$7,200 \div 12$$

- It costs £30 for one ticket to the zoo.  
How much do 7 tickets cost?  
How many tickets can you buy for £300?
- There are 120 children in Year 4  
The children are put into groups of 4  
How many groups are there altogether?



# Related facts – multiplication and division

## Reasoning and problem solving

9 friends are going to a theme park and having lunch.

Tickets to the theme park cost £30 each.

Lunch costs £10 each.

Six of the friends share the cost between them.

How much do they each pay?



£60

Is the statement true or false?

$$6 \times 800 = 8 \times 600$$

Explain your answer.



True

Write  $<$ ,  $>$  or  $=$  to compare the calculations.

$$72 \div 8 \quad \bigcirc \quad 720 \div 8$$

$$800 \div 2 \quad \bigcirc \quad 800 \div 4$$

$$4 \times 900 \quad \bigcirc \quad 9 \times 400$$

Did you need to work them out?



$<$

$>$

$=$

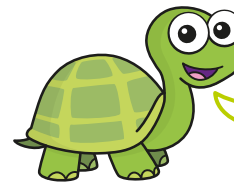

I know that  $5 \times 9 = 45$ , so I also know all these other facts.

$$\begin{array}{ll} 5 \times 90 = 450 & 450 \div 9 = 50 \\ 500 \times 9 = 4,500 & 4,500 \div 9 = 500 \end{array}$$

Do you agree with Tiny?

Explain your answer.



Yes

# Informal written methods for multiplication

## Notes and guidance

In this small step, children use a variety of informal written methods to multiply a 2-digit number by a 1-digit number.

Children follow a clear progression of methods and representations to support their understanding. They begin by using place value charts to recognise multiples of a number and make the link to repeated addition.

The use of base 10 encourages children to partition the tens and ones and unitise the tens, laying the foundations for later work. Part-whole models are used to illustrate the informal method of partitioning. Children use number lines, along with their knowledge of multiplying by 10. For example, to work out  $32 \times 4$  they count along a number line to show  $10 \times 4 + 10 \times 4 + 10 \times 4 + 2 \times 4$ . They may also use their knowledge of factor pairs from earlier in the block to multiply.

### Things to look out for

- Children may not use the correct place value, multiplying tens as ones, for example  $34 \times 6 = 3 \times 6 + 4 \times 6$
- Children may conflate the partitioning and factorising methods, for example when calculating  $4 \times 18$ , they may do  $4 \times 9 + 4 \times 2$

## Key questions

- What is the same and what is different about multiplying by 1s and multiplying by 10s?
- How would you explain this method?
- What is the most efficient way to work out  $\text{_____} \times \text{_____}$ ?
- How could you use a number line to work out this calculation?
- How could you use a part-whole model to partition into tens and ones?

## Possible sentence stems

- $\text{_____}$  partitioned into tens and ones is  $\text{_____}$  and  $\text{_____}$
- $\text{_____} \times \text{_____} = \text{_____}$  tens  $\times$   $\text{_____}$  +  $\text{_____}$  ones  $\times$   $\text{_____}$   
=  $\text{_____}$  tens +  $\text{_____}$  ones =  $\text{_____}$

### National Curriculum links

- Solve problems involving multiplying and adding, including using the distributive law to multiply 2-digit numbers by 1 digit, integer scaling problems and harder correspondence problems such as  $n$  objects are connected to  $m$  objects
- Recognise and use factor pairs and commutativity in mental calculations

# Informal written methods for multiplication

## Key learning

- Aisha uses base 10 to work out  $3 \times 26$

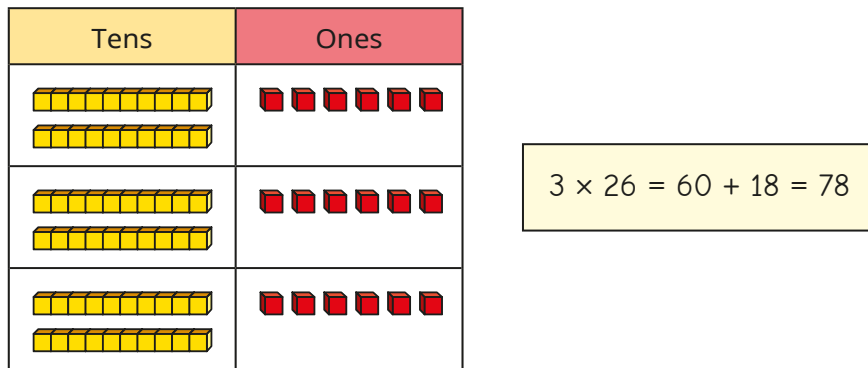

Use Aisha's method to work out the multiplications.

$3 \times 36$

$6 \times 24$

$4 \times 45$

- Teddy is using a number line to work out  $8 \times 26$

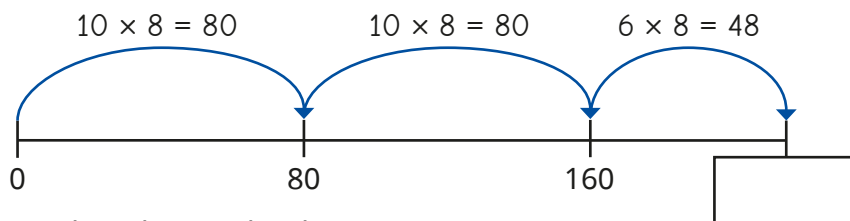

Complete the number line.

Use Teddy's method to work out the multiplications.

$7 \times 16$

$6 \times 34$

$4 \times 27$

- Ron is working out  $27 \times 5$

He partitions 27 into 20 and 7 and records this on a part-whole model.

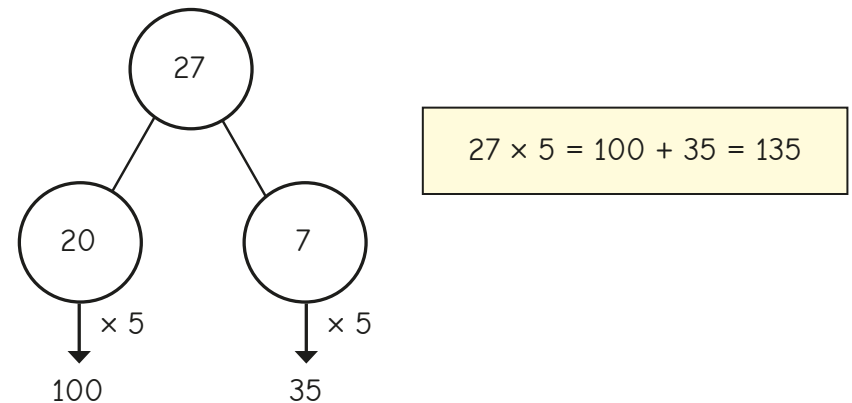

Use Ron's method to work out the multiplications.

$24 \times 8$

$36 \times 4$

$56 \times 3$

- There are 7 classes in a school.

Each class has 26 children.

How many children are there altogether?

# Informal written methods for multiplication

## Reasoning and problem solving

Rosie is using a part-whole model to work out 46 multiplied by 4

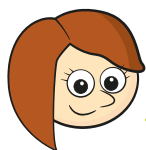
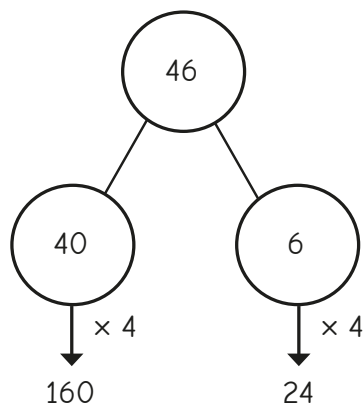

$46 \times 4 = 1,624$

What mistake has Rosie made?

What is the correct answer?

She has multiplied the parts correctly, but added them up incorrectly.

184

Dexter and Whitney are working out  $6 \times 14$



Dexter

I used a factor pair of 14 to help me: 2 and 7  
 $6 \times 2 = 12$   
 $12 \times 7 = 84$



Whitney

I partitioned 14 into 10 and 4  
 $6 \times 10 = 60$   
 $6 \times 4 = 24$   
 $60 + 24 = 84$

Whose method do you prefer? Why?

Use your preferred method to work out the multiplications.

$5 \times 43$

$16 \times 6$

$24 \times 3$

Talk about your methods with a partner.

215, 96, 72

# Multiply a 2-digit number by a 1-digit number

## Notes and guidance

In this small step, children progress from multiplying using informal written methods to the formal written method. The short multiplication method is introduced for the first time, initially in an expanded form and then in the formal short single-line form.

Children first do calculations where there are no exchanges, then move on to one and two exchanges. Place value counters in place value charts are used to illustrate the structure of the short multiplication by presenting the concrete model alongside the formal written method.

Concrete manipulatives alongside abstract calculations are particularly useful to support children's understanding of exchanges.

### Things to look out for

- Children may exchange ones or tens incorrectly, often by missing zeros or including zeros erroneously.
- Children may not include digits created through exchanging, either by not writing them down when completing the exchange or neglecting to include them in the calculation afterwards.
- When exchanges are performed, if digits are written in the incorrect place, this can lead to errors with the rest of the calculation.

## Key questions

- What is the same and what is different about multiplying by 1s and multiplying by 10s?
- How does the written method match the representation?
- Which column should you start with?
- What is the same and what is different about the different methods?

## Possible sentence stems

- \_\_\_\_\_ ones  $\times$  \_\_\_\_\_ = \_\_\_\_\_ ones,  
\_\_\_\_\_ tens  $\times$  \_\_\_\_\_ = \_\_\_\_\_ tens
- To multiply a 2-digit number by \_\_\_\_\_, you multiply the \_\_\_\_\_ by \_\_\_\_\_ and the \_\_\_\_\_ by \_\_\_\_\_
- \_\_\_\_\_ tens multiplied by \_\_\_\_\_ plus the ten I exchange is equal to \_\_\_\_\_ tens.

## National Curriculum links

- Multiply 2-digit and 3-digit numbers by a 1-digit number using formal written layout

# Multiply a 2-digit number by a 1-digit number

## Key learning

- Dora uses place value counters alongside the written multiplication to work out  $34 \times 2$

Tens	Ones
10 10 10	1 1 1 1
10 10 10	1 1 1 1

	T	O
	3	4
x		2
		8
	6	0
	6	8

( $4 \times 2 = 8$ )  
( $30 \times 2 = 60$ )

Use Dora's method to work out the multiplications.

$23 \times 3$	$32 \times 3$	$42 \times 2$
---------------	---------------	---------------

- Jo uses place value counters to work out  $24 \times 3$

Tens	Ones
10 10	1 1 1 1
10 10	1 1 1 1
10 10	1 1 1 1

	H	T	O
		2	4
x			3
		1	2
	6	0	
	7	2	

( $4 \times 3$ )  
( $20 \times 3$ )

Use Jo's method to work out the multiplications.

$6 \times 14$	$23 \times 4$	$18 \times 3$
---------------	---------------	---------------

- Brett and Scott have each worked out  $34 \times 5$

**Brett**

	H	T	O
		3	4
x			5
		2	0
	1	5	0
	1	7	0

( $4 \times 5$ )  
( $30 \times 5$ )

**Scott**

	H	T	O
		3	4
x			5
	1	7	0
	1	2	

- ▶ What is the same about their methods?
- ▶ What is different about their methods?
- ▶ Whose method is more efficient?

- Complete the multiplications.

	H	T	O
		4	3
x			5

	H	T	O
		3	6
x			4

	H	T	O
		7	4
x			5

# Multiply a 2-digit number by a 1-digit number

## Reasoning and problem solving

Here are three incorrect multiplications.

		H	T	O	
			6	1	
	x			5	
			3	5	

		H	T	O	
			7	4	
	x			7	
			4	9	8

		H	T	O	
			2	6	
	x			4	
			8	2	4

What mistakes have been made?

Complete the calculations correctly.



		H	T	O	
			6	1	
	x			5	
			3	0	5
			3		

		H	T	O	
			7	4	
	x			7	
			5	1	8
			2		

		H	T	O	
			2	6	
	x			4	
			1	0	4
			2		

Are the statements always true, sometimes true or never true?



When multiplying a 2-digit number by a 1-digit number, the product has three digits.

sometimes true

When multiplying a 2-digit number by 8, the product is an odd number.

never true

When multiplying a 2-digit number by 7, you will need to complete an exchange.

sometimes true

Explain how you know.



# Multiply a 3-digit number by a 1-digit number

## Notes and guidance

Following on from the previous step, children extend the formal written method to multiplying a 3-digit number by a 1-digit number. They continue to use the short multiplication method, but now with more columns. Children need to be secure with the previous step before moving on to this one.

Place value counters in place value charts are again used to model the structure of the formal method, allowing children to gain a greater understanding of the procedure, particularly where exchanges are needed. They continue to use the counters to exchange groups of 10 ones for 1 ten and also exchange 10 tens for 1 hundred and 10 hundreds for 1 thousand. This is mirrored by the positioning of the exchanged digit in the formal written method.

The focus here is on the short written method, but the expanded method could be used to support understanding for children who need it.

### Things to look out for

- The use of a zero in the ones or tens column can sometimes expose misunderstandings, as children can be unsure of multiplying by zero.
- Children may omit the exchange or include the exchange in an incorrect place on the formal written method.

## Key questions

- How could you use counters to represent the multiplication?
- How does the written method match the representation?
- Which column should you start with?
- Do you need to make an exchange? What exchange can you make?
- What is the same and what is different about multiplying a 3-digit number by a 1-digit number and multiplying a 2-digit number by a 1-digit number?

## Possible sentence stems

- \_\_\_\_\_ ones  $\times$  \_\_\_\_\_ = \_\_\_\_\_ ones  
\_\_\_\_\_ tens  $\times$  \_\_\_\_\_ = \_\_\_\_\_ tens  
\_\_\_\_\_ hundreds  $\times$  \_\_\_\_\_ = \_\_\_\_\_ hundreds
- \_\_\_\_\_ tens/hundreds multiplied by \_\_\_\_\_ plus the ten/  
hundred from the exchange is equal to \_\_\_\_\_

## National Curriculum links

- Multiply 2-digit and 3-digit numbers by a 1-digit number using formal written layout



# Multiply a 3-digit number by a 1-digit number

## Key learning

- Use the place value chart to help you complete the calculation.

Hundreds	Tens	Ones
100 100	10	1 1 1
100 100	10	1 1 1
100 100	10	1 1 1

	H	T	O	
	2	1	3	
	x		3	
<hr/>				
<hr/>				

- Use the place value chart to help you complete the calculation.

Hundreds	Tens	Ones
100 100 100	10 10	
100 100 100	10 10	
100 100 100	10 10	
100 100 100	10 10	

	Th	H	T	O
		3	2	0
	x			4
<hr/>				
<hr/>				

- Use place value counters and the written method to work out the multiplications.

$420 \times 3$

$4 \times 601$

$2 \times 530$

- A school has 4 house teams.  
There are 234 children in each house team.  
How many children are there altogether?

Hundreds	Tens	Ones
100 100	10 10 10	1 1 1 1
100 100	10 10 10	1 1 1 1
100 100	10 10 10	1 1 1 1
100 100	10 10 10	1 1 1 1

	H	T	O	
	2	3	4	
	x		4	
<hr/>				
<hr/>				

- Complete the calculations.

	H	T	O	
	2	0	5	
	x		3	
<hr/>				
<hr/>				

	H	T	O	
	1	4	8	
	x		6	
<hr/>				
<hr/>				

	H	T	O	
	7	4	6	
	x		5	
<hr/>				
<hr/>				

- Dani reads 164 pages of a book.  
Tom reads 3 times as many pages as Dani.  
How many pages does Tom read?  
How many pages do they read altogether?

# Multiply a 3-digit number by a 1-digit number

## Reasoning and problem solving

Sam and Jack have both completed the same multiplication.

**Sam**

	Th	H	T	O
		2	3	4
x				6
	1	2	0	4
		2	2	

**Jack**

	Th	H	T	O
		2	3	4
x				6
	1	4	0	4
		2	2	

Who has the correct answer?

What mistake did the other child make?

Jack

Sam did not add the 2 hundreds that she exchanged from the tens column.

Arrange the digit cards in the multiplication.



What is the greatest possible product?

Now arrange the cards to make the smallest possible product.

What strategies did you use?



$$642 \times 8 = 5,136$$

$$468 \times 2 = 936$$

$$321 \times 3 = 963$$

Without working it out, which would be greater,  $321 \times 4$  or  $322 \times 3$ ?

Check your answer by working it out.

$$321 \times 4$$

# Divide a 2-digit number by a 1-digit number (1)

## Notes and guidance

In this small step, children use their division facts from the Autumn term to build on their knowledge of dividing a 2-digit number by a 1-digit number from Year 3

Initially, children carry out divisions where the tens and ones are both divisible by the number being divided by without any remainders, for example  $96 \div 3$  and  $84 \div 4$ . They then move on to calculations where they need to exchange between tens and ones, for example  $96 \div 4$ . Place value counters are used to explore the sharing structure of division. Children do not need to use the formal short division method at this stage and may use informal jottings or representations such as a part-whole model to record their working instead.

## Things to look out for

- Children may partition the 2-digit number correctly, but then divide the tens as if they are ones, for example  $96 \div 3 = 9 \div 3 + 6 \div 3$
- Instead of using their times-tables knowledge, children may revert to less efficient methods such as drawing circles, then drawing dots to share between the circles.
- Children may always partition into tens and ones when other forms of partitioning are more appropriate.

## Key questions

- How do you partition a 2-digit number into tens and ones? How else can you partition a 2-digit number?
- Which is the most efficient way to partition the number so you can divide both parts by \_\_\_\_\_?
- If you cannot share all of the tens equally, what do you need to do?
- How can you represent the division using a part-whole model?

## Possible sentence stems

- \_\_\_\_\_ tens divided by \_\_\_\_\_ = \_\_\_\_\_ tens each
- \_\_\_\_\_ ones divided by \_\_\_\_\_ = \_\_\_\_\_ ones each
- I cannot share all of the tens equally, so I need to ...

## National Curriculum links

- Recall multiplication and division facts for multiplication tables up to  $12 \times 12$
- Use place value, known and derived facts to multiply and divide mentally, including: multiplying by 0 and 1; dividing by 1; multiplying together 3 numbers

# Divide a 2-digit number by a 1-digit number (1)

## Key learning

- Teddy uses a place value chart to divide 84 by 4

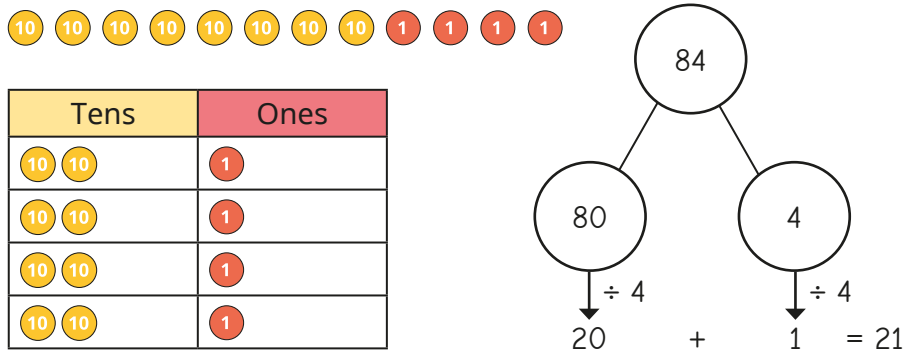

Use Teddy's method to work out the divisions.

$69 \div 3$	$88 \div 4$	$96 \div 3$
-------------	-------------	-------------

- Complete the calculations.

- $46 \div 2 =$  \_\_\_\_\_ tens  $\div 2$  and \_\_\_\_\_ ones  $\div 2$   
 = \_\_\_\_\_ tens and \_\_\_\_\_ ones  
 = \_\_\_\_\_
  - $63 \div 3 =$  \_\_\_\_\_ tens  $\div 3$  and \_\_\_\_\_ ones  $\div 3$   
 = \_\_\_\_\_ tens and \_\_\_\_\_ ones  
 = \_\_\_\_\_

- Eva uses place value counters to work out 96 divided by 4

First, she divides the tens.

She has one ten remaining.

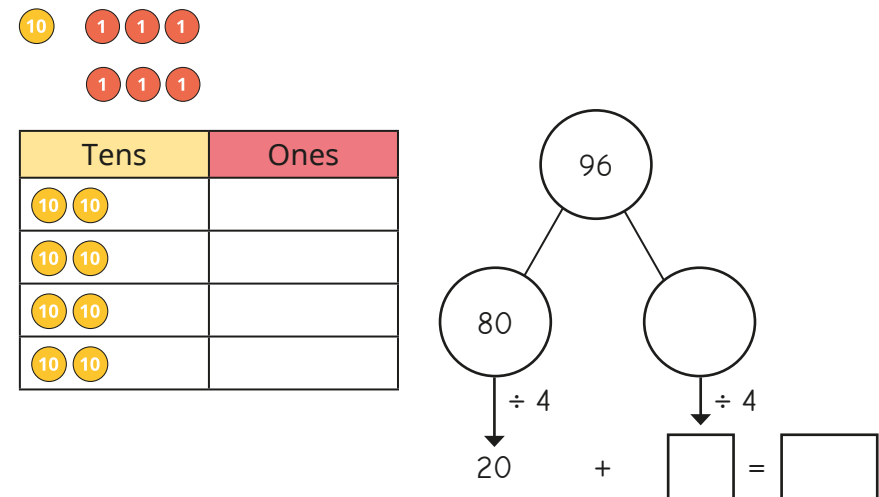

- What should Eva do with the remaining ten?

Complete Eva's workings.

- Use Eva's method to work out the divisions.

$84 \div 7$	$78 \div 6$	$96 \div 8$
-------------	-------------	-------------

# Divide a 2-digit number by a 1-digit number (1)

## Reasoning and problem solving

Tiny is working out  $72 \div 3$

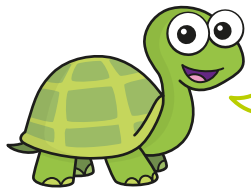

I will need to make an exchange.

Yes

Do you agree with Tiny?

Explain your answer.



Write  $<$ ,  $>$  or  $=$  to compare the calculations.

$69 \div 3$  ○  $96 \div 3$

$96 \div 4$  ○  $96 \div 3$

$91 \div 7$  ○  $84 \div 6$

$<$

$<$

$<$

Kim has 96 sweets.

She shares them into equal groups.

She has no sweets left over.

How many equal groups could Kim have shared her sweets into?



1, 2, 3, 4, 6, 8, 12,  
16, 24, 32, 48 or 96  
groups

Here are two ways of partitioning 85 to help work out  $85 \div 5$

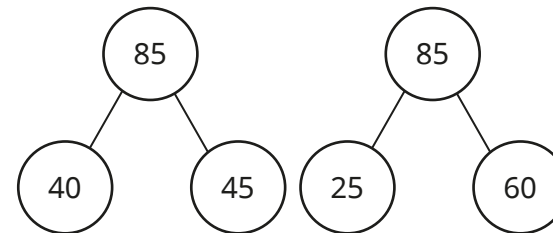

What other ways could you partition 85 to help with the division?

Which way do you prefer?



multiple possible  
answers, e.g.

10 and 75

80 and 5

50 and 25

# Divide a 2-digit number by a 1-digit number (2)

## Notes and guidance

In this small step, children continue to explore dividing a 2-digit number by a 1-digit number, but in this step the focus is on calculations with remainders.

Children encountered remainders in Year 3, so this concept is not new but it may need reinforcing.

Using place value counters to illustrate the sharing structure of division helps children to see what is meant by the remainder. Such representations should highlight the fact that the remainder can never be greater than the number they are dividing by.

## Things to look out for

- Children may not fully divide and so will have a remainder that is greater than the number they are dividing by.
- Children may partition the 2-digit number correctly, but then divide the tens as if they are ones, for example  $95 \div 3 = 9 \div 3 + 5 \div 3$
- Children may revert to less efficient methods, such as drawing circles and then drawing dots to share between the circles.
- Children may divide the whole number rather than partitioning into tens and ones and then unitising the tens.

## Key questions

- Can the counters be shared equally? If not, how many are left over?
- What does “remainder” mean?
- What is the greatest remainder you can have when you are dividing by \_\_\_\_\_?
- How can you partition a 2-digit number?
- If you cannot share all the tens equally, what do you need to do?
- If you cannot share all the ones equally, what happens?
- How do you know that  $43 \div 2$  will have a remainder?

## Possible sentence stems

- If I am dividing by \_\_\_\_\_, then the greatest possible remainder is \_\_\_\_\_

## National Curriculum links

- Recall multiplication and division facts for multiplication tables up to  $12 \times 12$
- Use place value, known and derived facts to multiply and divide mentally, including: multiplying by 0 and 1; dividing by 1; multiplying together 3 numbers

# Divide a 2-digit number by a 1-digit number (2)

## Key learning

- Tommy uses place value counters to divide 85 by 4



Tens	Ones
10 10	1
10 10	1
10 10	1
10 10	1

First, he shares the tens.  
Then he shares the ones.  
He has 1 one left over.



$$85 \div 4 = 21 \text{ r}1$$

Use Tommy's method to work out the divisions.

$$49 \div 2$$

$$95 \div 3$$

$$58 \div 5$$

- Work out the divisions.

- ▶  $86 \div 4$       ▶  $94 \div 3$
- ▶  $87 \div 4$       ▶  $95 \div 3$
- ▶  $88 \div 4$       ▶  $97 \div 3$
- ▶  $89 \div 4$       ▶  $98 \div 3$
- ▶  $90 \div 4$       ▶  $99 \div 3$

What do you notice?

- Alex uses place value counters to work out  $97 \div 4$

Tens	Ones
10 10	1 1 1 1
10 10	1 1 1 1
10 10	1 1 1 1
10 10	1 1 1 1

10

$$97 \div 4 = 24 \text{ r}1$$

Why has Alex made an exchange?

Use Alex's method to work out the divisions.

$$57 \div 4$$

$$49 \div 3$$

$$68 \div 5$$

- Complete the divisions.

- ▶  $83 \div 3 = \text{_____} \text{ r} \text{_____}$       ▶  $\text{_____} \div 6 = 11 \text{ r}2$
- ▶  $95 \div 4 = \text{_____} \text{ r}3$       ▶  $\text{_____} \div 7 = 7 \text{ r}6$

- There are 95 pencils.

They are shared equally between 4 pots.

How many pencils will be left over?

# Divide a 2-digit number by a 1-digit number (2)

## Reasoning and problem solving

Filip is thinking of a 2-digit number that is less than 50

Work out Filip's number from the clues:

- When it is divided by 2, there is no remainder.
- When it is divided by 3, there is a remainder of 1
- When it is divided by 5, there is a remainder of 3

28

$85 \div 3 = 28 \text{ r}1$

85 must be 1 more than a multiple of 3

Is Rosie correct?  
Explain your answer.

Yes

Whitney and Ron are working out  $37 \div 4$

Whitney: The answer is 8 r1

Ron: The answer is 8 r5

Both children are incorrect. Explain the mistakes they have made. What is the correct answer?

9 r1



# Divide a 3-digit number by a 1-digit number

## Notes and guidance

In this small step, children continue to develop their understanding of division by extending from dividing 2-digit numbers in the previous two steps to dividing 3-digit numbers.

Place value counters are again used to represent the calculations, so that children can make sense of exchanges that are needed to complete the division.

Part-whole models are also used to show how flexible partitioning can support the process of division by looking for multiples of the number being divided by.

The step starts with divisions that do not leave a remainder, before progressing to divisions with remainders.

By the end of this step, children should have a good understanding of division that will support them when they move on to the formal written method in Year 5

## Things to look out for

- Children may partition the 3-digit number correctly, but then divide the hundreds and tens as if they are ones, for example  $846 \div 2 = 8 \div 2 + 4 \div 2 + 6 \div 2$
- Children may divide the whole number rather than partitioning into hundreds, tens and ones and then unitising the hundreds and tens.

## Key questions

- How do you partition a 3-digit number into hundreds, tens and ones?
- How else can you partition a 3-digit number?
- What is the best way to partition the number to help you work out the division?
- If you cannot share all of the hundreds/tens equally, what do you need to do?
- How can you represent the division using a part-whole model?

## Possible sentence stems

- \_\_\_\_\_ hundreds divided by \_\_\_\_\_ = \_\_\_\_\_ hundreds
- \_\_\_\_\_ tens divided by \_\_\_\_\_ = \_\_\_\_\_ tens
- \_\_\_\_\_ ones divided by \_\_\_\_\_ = \_\_\_\_\_ ones
- There is \_\_\_\_\_ left over, so I need to exchange it for \_\_\_\_\_

## National Curriculum links

- Recall multiplication and division facts for multiplication tables up to  $12 \times 12$
- Use place value, known and derived facts to multiply and divide mentally, including: multiplying by 0 and 1; dividing by 1; multiplying together 3 numbers

# Divide a 3-digit number by a 1-digit number

## Key learning

- Annie uses place value counters to divide 639 by 3

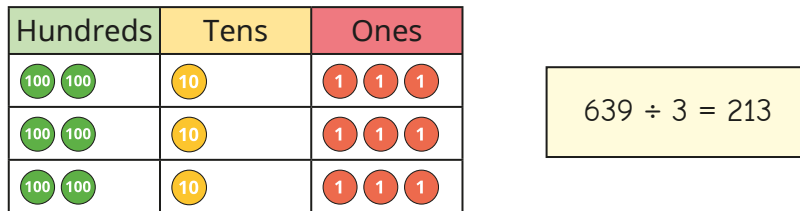

Use Annie's method to work out the divisions.

862 ÷ 2

884 ÷ 4

906 ÷ 3

630 ÷ 3

- Mo uses a part-whole model to work out 646 ÷ 2

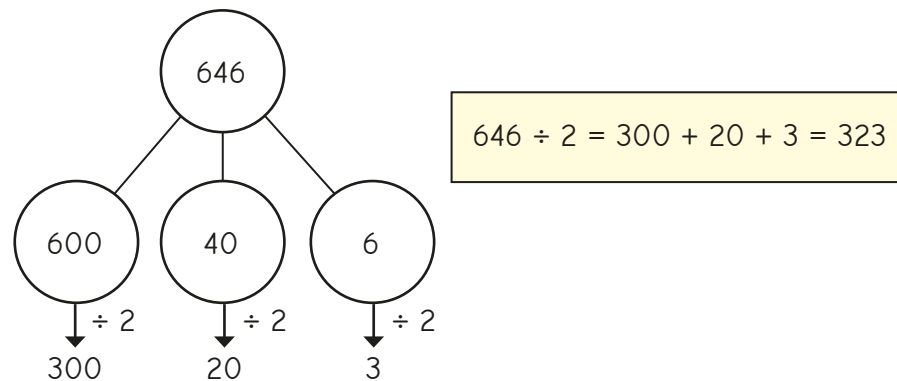

Use Mo's method to work out the divisions.

428 ÷ 2

963 ÷ 3

840 ÷ 4

399 ÷ 3

- Rosie uses place value counters to work out 435 ÷ 3

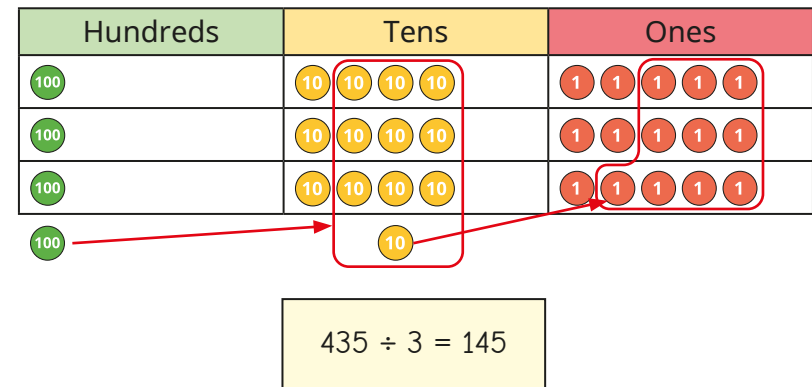

Use Rosie's method to work out the divisions.

528 ÷ 2

672 ÷ 6

934 ÷ 4

- Tiny is using a part-whole model to work out 135 ÷ 3

Why has Tiny partitioned 135 this way?

Complete Tiny's workings.

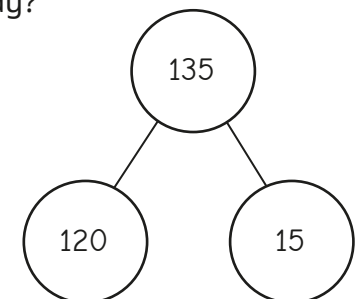

# Divide a 3-digit number by a 1-digit number

## Reasoning and problem solving

Max and Jo are working out  $208 \div 8$   
They have each partitioned 208 differently.

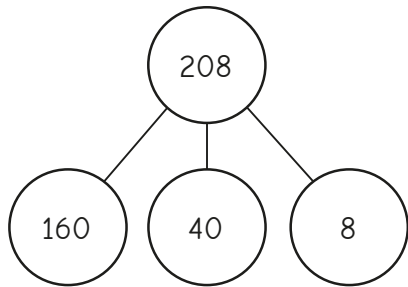
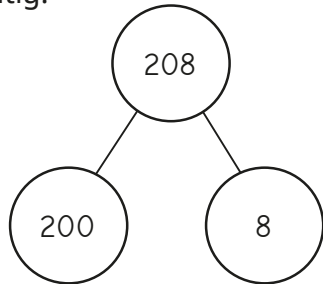

Work out the division using both methods.

What do you notice?

Which method do you prefer?



26

The answer is the same for both methods.

Use 12 counters and the place value chart to make the numbers described.

Use all 12 counters to make each number.

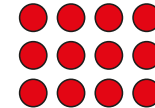

H	T	O

- a 3-digit number divisible by 2
- a 3-digit number divisible by 3
- a 3-digit number divisible by 4
- a 3-digit number divisible by 5

Is it possible to make 3-digit numbers that are divisible by 6, 7, 8 or 9?



2: any even number

3: any 3-digit number (as the digits add up to 12, which is a multiple of 3)

4: a number where the last two digits are a multiple of 4

5: any number with 0 or 5 in the ones column

# Correspondence problems

## Notes and guidance

In this small step, children consolidate their understanding of correspondence problems from Year 3, using multiplication to work out the number of possible combinations of sets of items.

Children use a range of representations and contexts to support them. Using tables helps to encourage children to adopt a systematic approach to finding all of the possible combinations in a given context. Children then generalise to make the link between the number of possibilities for each item and using multiplication to find the total number of combinations.

Once confident with finding all possible combinations for two sets of items children may begin to explore finding all possible combinations for three sets of items.

### Things to look out for

- Children may see the same choices in a different order as a different choice.
- Children may need support to work systematically when listing all possibilities.
- Children may add instead of multiply the number of possibilities for each item.

## Key questions

- How can you use a table to help you find the possible combinations?
- How can you be sure that you have listed all the possibilities?
- How could you use a code to help you list the combinations?
- What do you notice about the number of choices for each item and the total number of combinations?
- How can you check your answer?
- Does the order in which you make your choices matter?

## Possible sentence stems

- For every \_\_\_\_\_, there are \_\_\_\_\_ \_\_\_\_\_
- Altogether, there are \_\_\_\_\_  $\times$  \_\_\_\_\_ = \_\_\_\_\_ possible combinations.

## National Curriculum links

- Solve problems involving multiplying and adding, including using the distributive law to multiply 2-digit numbers by 1 digit, integer scaling problems and harder correspondence problems such as  $n$  objects are connected to  $m$  objects

# Correspondence problems

## Key learning

- A cafe has 4 flavours of ice cream and 2 choices of toppings.

Ice cream flavours	Toppings
vanilla	sauce wafer
chocolate	
strawberry	
lemon	

- Complete the table to show the 8 possible combinations of flavours and toppings.

	Sauce	Wafer
Vanilla		VW
Chocolate		
Strawberry		SW
Lemon	LS	

- What multiplication could you use to work out the total number of combinations?  
How do you know?
- How many combinations would there be if the cafe also offered mint ice cream?
- How many combinations would there be if there were 6 ice cream flavours and 3 different toppings?

- Huan has two piles of coins. He chooses one coin from each pile.

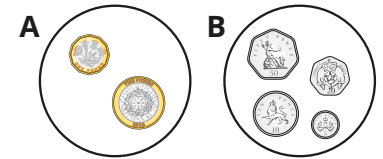

- List all the possible combinations of coins Huan could choose.
  - How many different combinations of coins are there?
  - List all the possible total amounts of money Huan can make.
  - How many different total amounts of money are there?
- Esther is choosing what to wear on a snowy day.

Hat	Scarf	Gloves

- How many different ways can Esther choose a hat and a scarf?
- How many different ways can Esther choose a hat and a pair of gloves?
- How many different ways can Esther choose a hat, a scarf and a pair of gloves?

How can you check your answers?

# Correspondence problems

## Reasoning and problem solving

Here are the meal choices in the school canteen.

Starter	Main	Dessert
soup	pasta	cake
garlic bread	chicken	ice cream
	beef	fruit salad
	salad	

Children can make one choice from each section.

How many possible combinations of starters, mains and desserts can be chosen?

If there were 20 possible meal combinations, how many starters, mains and desserts could there be?



24

multiple possible answers, e.g.

1S, 1M, 20D

1S, 2M, 10D

1S, 4M, 5D

2S, 2M, 5D

1S, 20M, 1D

Brett has 6 T-shirts and 4 pairs of shorts.

Dani has 12 T-shirts and 2 pairs of shorts.

Who has the most combinations of T-shirts and shorts?

Explain your answer.



They have the same.

Jo rolls two 6-sided dice and multiplies the numbers together.



There are  $6 \times 6 = 36$  different possible answers Jo could get.

18

Explain why Tiny is wrong.

How many different answers could Jo get?



# Efficient multiplication

## Notes and guidance

In this small step, children consolidate their knowledge and understanding of multiplication and begin to make decisions regarding the most efficient or appropriate methods to use in a range of contexts.

Children look at times-tables facts, building strategies for finding unknown facts that will support them to strengthen their fluency of times-tables. They then examine a range of strategies for multiplying a 2-digit number by a 1-digit number. Finally, they use arrays to explore multiplicative structure, in particular the associative law and distributive law.

### Things to look out for

- Children may conflate different methods, leading to misunderstanding.
- Children may partition the numbers correctly, but then multiply the tens as if they are ones, for example  $34 \times 6 = 3 \times 6 + 4 \times 6$
- Children may attempt to learn the different methods procedurally. It is vital that children understand how they are manipulating the numbers, rather than try to remember a long series of instructions.

## Key questions

- Which method do you find most efficient? Explain how this method works.
- What is the most efficient way to work out  $\_\_\_\_\_ \times \_\_\_\_\_$ ?
- What happens if you double one factor and halve the other?
- How could you use factor pairs to help you calculate?

## Possible sentence stems

- $\_\_\_\_\_ \times \_\_\_\_\_ = \_\_\_\_\_ \times \_\_\_\_\_ + \_\_\_\_\_ \times \_\_\_\_\_$
- $\_\_\_\_\_ \times \_\_\_\_\_ = \_\_\_\_\_ \times \_\_\_\_\_ - \_\_\_\_\_ \times \_\_\_\_\_$
- $\_\_\_\_\_ \times \_\_\_\_\_ = \_\_\_\_\_ \times \_\_\_\_\_ \times 2$
- $\_\_\_\_\_ \times \_\_\_\_\_ = \_\_\_\_\_ \times \_\_\_\_\_ \div 2$

## National Curriculum links

- Solve problems involving multiplying and adding, including using the distributive law to multiply 2-digit numbers by 1 digit, integer scaling problems and harder correspondence problems such as  $n$  objects are connected to  $m$  objects

# Efficient multiplication

## Key learning

- Jack and Sam are working out  $7 \times 6$



Jack

To work out  $7 \times 6$ ,  
I do  $7 \times 3 = 21$ ,  
then double  $21 = 42$



Sam

To work out  $7 \times 6$ ,  
I do  $7 \times 5 = 35$ ,  
then add  $7 = 42$

- ▶ Use Jack's method to work out  $8 \times 6$
- ▶ Use Sam's method to work out  $9 \times 6$

- For each calculation, show two ways that you could find the answer if you do not know the times-table fact.

$9 \times 4$

$9 \times 7$

$4 \times 7$

$7 \times 8$

- Work out the missing numbers.

▶  $5 \times 8 = 5 \times 4 \times \underline{\quad}$

▶  $16 \times 5 = 16 \times 10 \div \underline{\quad}$

▶  $7 \times 4 = 7 \times 2 \times \underline{\quad}$

▶  $19 \times 7 = 20 \times 7 - \underline{\quad} \times 7$

- Here are four different ways of working out  $15 \times 8$  mentally. Complete the calculation in each method.

### Method 1

$$\begin{aligned} 15 \times 8 &= 10 \times 8 + 5 \times 8 \\ &= 80 + \underline{\quad} \\ &= \underline{\quad} \end{aligned}$$

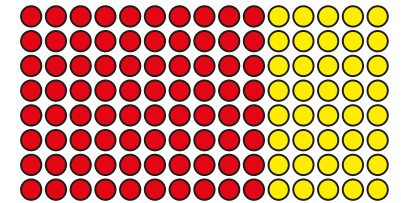

### Method 2

$$\begin{aligned} 15 \times 8 &= 3 \times 5 \times 8 \\ &= 3 \times \underline{\quad} \\ &= \underline{\quad} \end{aligned}$$

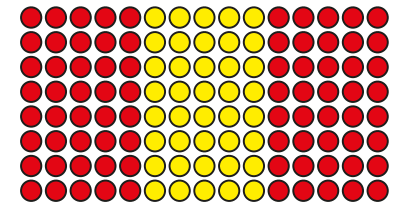

### Method 3

$$\begin{aligned} 15 \times 8 &= 15 \times 10 - 15 \times 2 \\ &= \underline{\quad} - \underline{\quad} \\ &= \underline{\quad} \end{aligned}$$

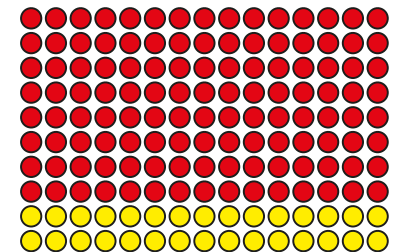

### Method 4

$$\begin{aligned} 15 \times 8 &= 30 \times 8 \div 2 \\ &= \underline{\quad} \div 2 \\ &= \underline{\quad} \end{aligned}$$



# Efficient multiplication

## Reasoning and problem solving

Find four different ways to work out  $18 \times 5$

Compare methods with a partner.



multiple possible answers, e.g.  $(18 \times 10) \div 2$

Kim uses an array to help her work out  $19 \times 3$

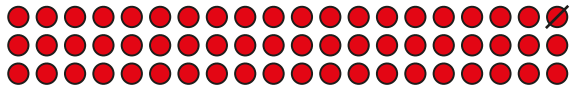

$$20 \times 3 = 60$$

$$60 - 1 = 59$$

$$19 \times 3 = 59$$

Kim has subtracted one counter, rather than one group of 3 counters.

What mistake has Kim made?

Draw or make the array correctly.



Teddy, Eva and Amir choose one of the number cards each.

They multiply their number by 5

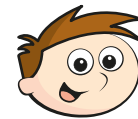

I did  $40 \times 5$  and then subtracted 2 lots of 5

Teddy

42

I multiplied my number by 10 and then divided 210 by 2

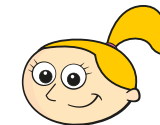

Eva

Which number card has Amir got?

Talk about the different methods Amir could have used.



Spring Block 2

**Length and perimeter**

## Small steps

Step 1

Measure in kilometres and metres

Step 2

Equivalent lengths (kilometres and metres)

Step 3

Perimeter on a grid

Step 4

Perimeter of a rectangle

Step 5

Perimeter of rectilinear shapes

Step 6

Find missing lengths in rectilinear shapes

Step 7

Calculate perimeter of rectilinear shapes

Step 8

Perimeter of regular polygons



## Small steps

Step 9

Perimeter of polygons



# Measure in kilometres and metres

## Notes and guidance

In previous years, children measured lengths using metres (m) and centimetres (cm). In this small step, children are introduced to kilometres and the abbreviation “km”.

Children should understand that kilometres are greater than metres and are used to measure greater distances. The focus of this step is to partition measurements into the number of kilometres and metres and make links with addition. Bar models and part-whole models can be used to explore this relationship and to support children with their understanding. The fact that  $1 \text{ km} = 1,000 \text{ m}$  can be discussed, but conversions are not explicitly covered until the next step.

It is useful to make connections with real-life contexts, so that children are aware when different types of units are used.

### Things to look out for

- Children may ignore the unit of measurement and just compare the numbers involved. For example, they might think that 2 km and 60 m is less than 1 km and 700 m, because 260 is less than 1,700
- Children may think that  $1 \text{ km} = 100 \text{ m}$ , based on the relationship between metres and centimetres.

## Key questions

- What unit of measurement would you use to measure the length of a \_\_\_\_\_? Why?
- What unit of measurement would you use to measure \_\_\_\_\_? Why?
- Which is the greater length, 1 km or 1 m?
- Which is greater, \_\_\_\_\_ km and \_\_\_\_\_ m or \_\_\_\_\_ km and \_\_\_\_\_ m? How do you know?
- Which is greater, \_\_\_\_\_ km or \_\_\_\_\_ m? How do you know?
- How many kilometres and metres are there in \_\_\_\_\_ km \_\_\_\_\_ m?

## Possible sentence stems

- \_\_\_\_\_ km \_\_\_\_\_ m = \_\_\_\_\_ km + \_\_\_\_\_ m
- \_\_\_\_\_ km and \_\_\_\_\_ m is greater than \_\_\_\_\_ km and \_\_\_\_\_ m.
- \_\_\_\_\_ km and \_\_\_\_\_ m is less than \_\_\_\_\_ km and \_\_\_\_\_ m.
- There are \_\_\_\_\_ m in 1 km.

### National Curriculum links

- Convert between different units of measure [for example, kilometre to metre; hour to minute]

# Measure in kilometres and metres

## Key learning

- Sort the cards into the table to show the appropriate unit of measurement.

height of a door frame	length of a room
how far a plane travels	length of a garden
distance from one city to another	length of a table
distance from the bottom to the top of a mountain	
Measured in kilometres	Measured in metres

- Use abbreviations to complete the sentences.

The distance from Rosie's house to school is six kilometres and five hundred metres.

The distance from Rosie's house to school is 6 \_\_\_\_\_ 500 \_\_\_\_\_

Jack cycled a total of 8 kilometres and 150 metres to school.

Jack cycled a total of \_\_\_\_\_ km \_\_\_\_\_ \_\_\_\_\_ to school.

- Complete the models.

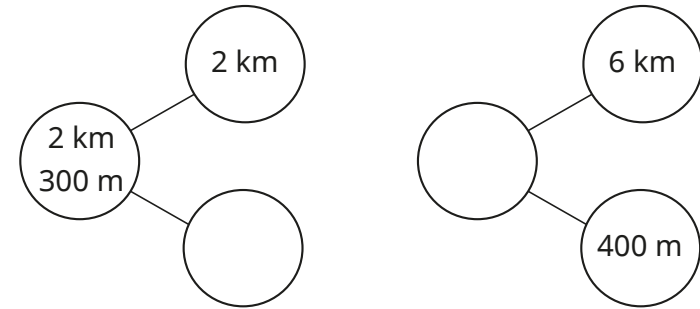

3 km 300 m		1 km 280 m	
km	300 m	m	1 km

- Which is the greater length, 30 m or 3 km? How do you know?
- Write  $<$ ,  $>$  or  $=$  to complete the statements.

4 km and 300 m  3 km

9 km and 600 m  9 km + 60 m

5 km and 500 m  2 km + 3 km + 500 m

# Measure in kilometres and metres

## Reasoning and problem solving

Tiny is measuring the length of a swimming pool.

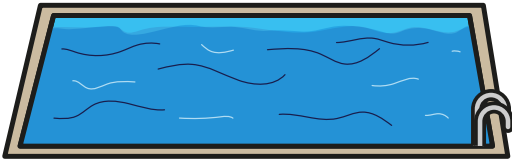

I am going to measure the length in kilometres.

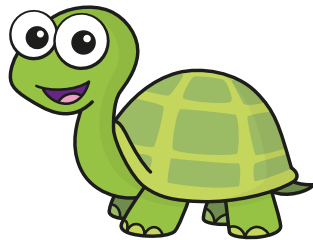

Do you think Tiny has chosen the best unit to measure the length of the pool?

Explain your answer.



No

Teddy walks to his friend's house.



- He walks a whole number of kilometres.
- He walks an odd number of kilometres.
- He walks further than 2 km, but less than 17 km.
- The distance is a multiple of 3

Use the clues to find three possible distances that Teddy walks.

3 km, 9 km  
or 15 km

One day, Dora cycles 8 km 200 m.



The next day she cycles 300 m further.

How far does Dora cycle altogether over the two days?

How did you work it out?



16 km 700 m

# Equivalent lengths (kilometres and metres)

## Notes and guidance

In Year 3, children converted between metres and centimetres, and between centimetres and millimetres. In this small step, children use the fact that 1 km is equal to 1,000 m to derive related facts using numbers up to 10,000

Children make links to counting in 1,000s as covered in their earlier learning on place value.

Bar models, part-whole models and double number lines are useful representations to explore the connections between the two units and to support children with conversions.

Children learnt to multiply and divide by 10 and 100 in the previous block and could extend their thinking to multiply and divide by 1,000; if this is not appropriate, they could count up and down in 1,000s instead.

## Things to look out for

- Children may mix up the conversions between different metric units, for example thinking that 1 km = 100 m.
- Children may make errors when counting in 1,000s.
- Children may just consider the numbers and not the units and think that, for example, 70 m is greater than 7 km as 70 is greater than 7

## Key questions

- How many metres are there in 1 km?  
So how many metres are there in \_\_\_\_\_ km?
- How can you work out how many metres is equivalent to half a kilometre?  
What other fractions of a kilometre can you convert to metres?
- Which is greater, \_\_\_\_\_ km or \_\_\_\_\_ m? How do you know?
- What is the same and what is different about converting metres to centimetres and converting kilometres to metres?

## Possible sentence stems

- There are \_\_\_\_\_ m in 1 km, so there are \_\_\_\_\_ m in \_\_\_\_\_ km.
- Each kilometre is \_\_\_\_\_ m, so \_\_\_\_\_ km is the same as \_\_\_\_\_ m.
- Every 1,000 m is \_\_\_\_\_ km, so \_\_\_\_\_ m is the same as \_\_\_\_\_ km.
- \_\_\_\_\_ km and \_\_\_\_\_ m is the same as \_\_\_\_\_ m.

## National Curriculum links

- Convert between different units of measure [for example, kilometre to metre; hour to minute]



# Equivalent lengths (kilometres and metres)

## Key learning

- Use the double number line to complete the number sentences.

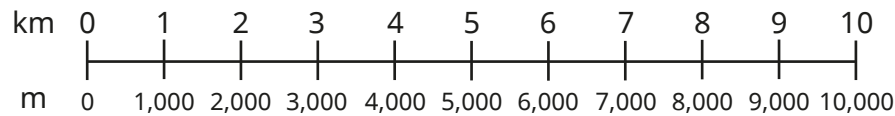

- ▶ 1,000 m = \_\_\_\_\_ km
- ▶ 3,000 m = \_\_\_\_\_ km
- ▶ \_\_\_\_\_ m = 4 km
- ▶ \_\_\_\_\_ m = 10 km

- Use the bar models to complete the conversions.

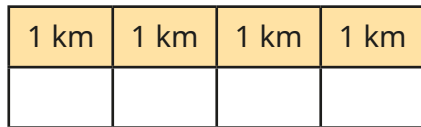

4 km = \_\_\_\_\_ m

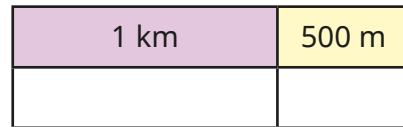

1 km and 500 m = \_\_\_\_\_ m

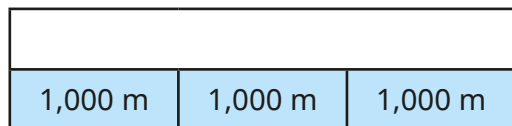

3,000 m = \_\_\_\_\_ km

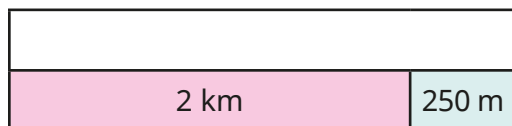

2 km and 250 m = \_\_\_\_\_ m

- Complete the conversions.

- ▶ 2 km 100 m = \_\_\_\_\_ m
- ▶ \_\_\_\_\_ km \_\_\_\_\_ m = 2,050 m
- ▶ 4 km 300 m = \_\_\_\_\_ m
- ▶ \_\_\_\_\_ km \_\_\_\_\_ m = 4,030 m

- Complete the statement.

800 m + 600 m = \_\_\_\_\_ m = \_\_\_\_\_ km \_\_\_\_\_ m

- Complete the bar models.

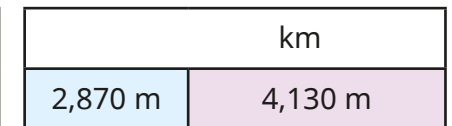
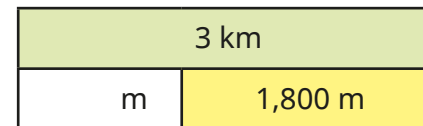

- Write <, > or = to compare the lengths.

6 km and 500 m ○ 6,500 m

4 km ○ 350 m

$\frac{1}{2}$  km ○ 120 m

# Equivalent lengths (kilometres and metres)

## Reasoning and problem solving

Tom is running a cross-country race. 

He runs 800 m as a warm-up.

The race is 5,600 m.

He then does a cool-down of 1 km 200 m.

How far does Tom run in total?

Give your answer in metres.

7,600 m

1,600 m is greater than 6 km.

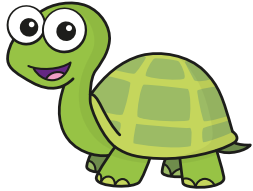

Do you agree with Tiny?

Explain your answer. 

No

Max and Aisha take part in a charity walk. 

They walk 15 km altogether. 

Aisha walks twice as far as Max.

How far do they each walk?

Max: 5 km  
Aisha: 10 km

Max and Aisha both raise £1 for every 500 m they walk.

How much money do they each raise?

Max: £10  
Aisha: £20

The flying distance from London to Paris is 342 km 760 m.

The driving distance from London to Paris is 475 km 537 m.

How much further is the driving distance than the flying distance?

132 km 777 m

# Perimeter on a grid

## Notes and guidance

In Year 3, children were introduced to the idea of perimeter by measuring and calculating the perimeter with labelled side lengths. In this small step, children explore perimeter further with a focus on rectilinear shapes, where all sides meet at right angles. These rectilinear shapes will be drawn on squared grids, mainly centimetre squared grids.

Encourage children to label the lengths of the sides if needed, and to mark off each side as they add the lengths together. Looking at a variety of shapes enables children to compare their perimeters. They also explore drawing different shapes with a specified perimeter. They continue to consider rectilinear shapes only and do not look at diagonal lengths.

### Things to look out for

- Children may only add the width and length of one side, or the sides labelled, rather than all the sides of the shape.
- Children may forget to include the unit of measurement.
- Children may count all the squares around the outside of the shape, rather than the lengths of the sides.
- When looking at irregular rectilinear shapes, children may miss some of the sides of the shape.

## Key questions

- What does “perimeter” mean?
- What is the length of each square? How do you know?
- What is the length of each side? How do you know?
- What unit is used for the perimeter of your shape?
- How can you make sure you do not include one side twice?
- Which shape has the greater/greatest perimeter?  
How do you know?
- Can two different shapes have the same perimeter? How do you know? Can you draw an example to support your answer?

## Possible sentence stems

- Perimeter = \_\_\_\_\_ cm + \_\_\_\_\_ cm + \_\_\_\_\_ cm + \_\_\_\_\_ cm = \_\_\_\_\_ cm
- The width is \_\_\_\_\_ cm and the length is \_\_\_\_\_ cm.  
The perimeter of the shape is \_\_\_\_\_ cm because ...

## National Curriculum links

- Measure and calculate the perimeter of a rectilinear figure (including squares) in centimetres and metres

# Perimeter on a grid

## Key learning

- Work out the perimeters of the shapes.

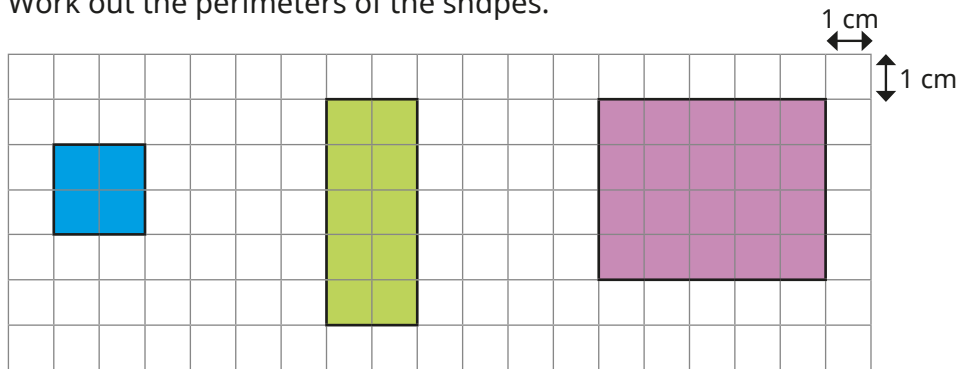

- Two rectilinear shapes are drawn on centimetre squared paper.

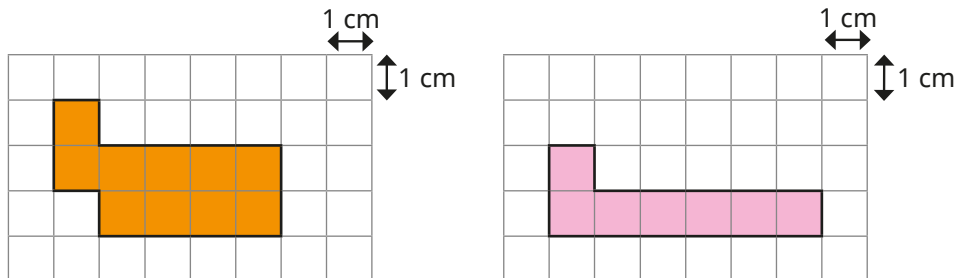

- Are the perimeters of the shapes the same or different?  
How do you know?
- Draw a shape with a perimeter that is greater than each of the shapes.

- Work out the perimeters of the shapes.

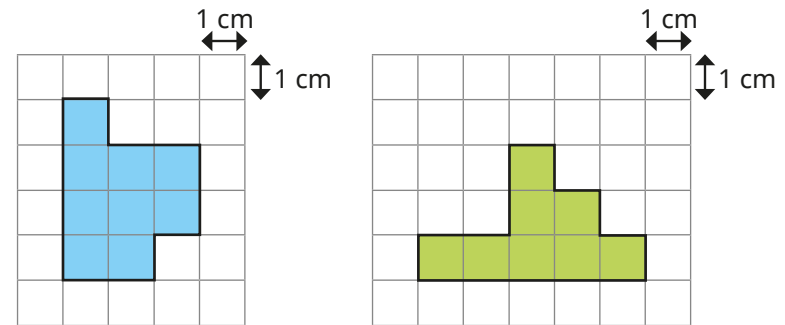

How did you find the perimeters?

- Find the perimeter of each shape.

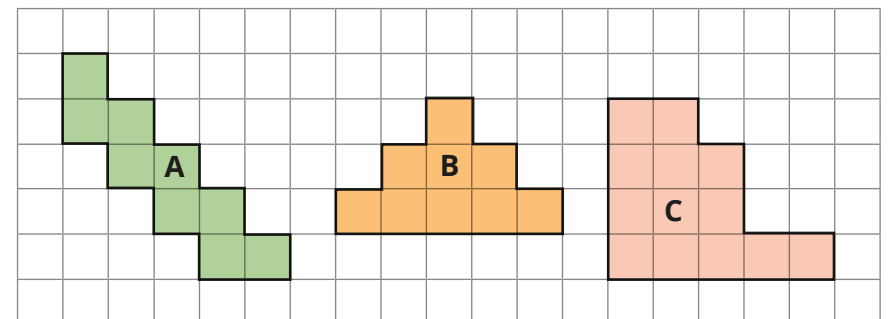

Order the shapes from smallest to greatest perimeter.

- Use centimetre squared paper to draw two different rectilinear shapes, each with a perimeter of 18 cm.

# Perimeter on a grid

## Reasoning and problem solving

Tiny has worked out the perimeter of the shape to be 22 cm.

22	1	2	3				
21			4	5	6	7	8
20							9
19	18	17	16			11	10
			15	14	13	12	

Is Tiny correct?

Explain your reasoning.

No

The width of a rectangle is 2 cm less than its length.

The perimeter of the rectangle is between 20 cm and 30 cm.

What could the dimensions of the rectangle be?

How many possible rectangles can you find?

length = 6 cm,  
width = 4 cm

length = 7 cm,  
width = 5 cm

length = 8 cm,  
width = 6 cm

Huan has drawn a shape on a centimetre squared grid.

He has spilt some paint on his drawing.

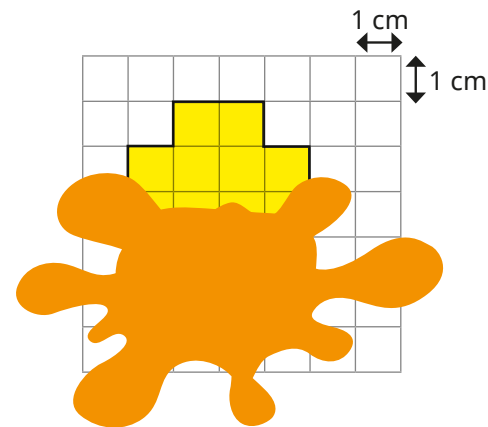

What could the perimeter of the shape be?

Find three possible answers.

What is the smallest possible perimeter?

Explain your answer.

Compare answers as a class.

14 cm

# Perimeter of a rectangle

## Notes and guidance

In this small step, children focus on calculating the perimeter of rectangles using the side lengths, rather than counting the squares.

Rectangles are first presented on squared grids as they have been seen previously. Children should be encouraged to label the side lengths on the rectangles and discuss anything they notice as they work through some examples. They can then progress to looking at rectangles that are not presented on squared grids but with all four sides labelled, before finally exploring rectangles with only one length and width given.

Children explore different methods for working out the perimeter of rectangles, such as adding double the length to double the width, and doubling the sum of the length and the width.

### Things to look out for

- Children may only add the lengths of the sides that are labelled rather than using more efficient methods involving multiplication.
- Children may not check the units given in the diagrams and so fail to convert them if there are mixed units.
- If children do not have efficient strategies for doubling 1- and 2-digit numbers then this may lead to a reliance on inefficient methods.

## Key questions

- What is the length of each side? How do you know?
- How can you use the length of each side to calculate the perimeter?
- What is the measurement unit used for the perimeter of the rectangle?
- How did you work out the perimeter of the rectangle? How could you have done it a different way?
- If you know the length and width of a rectangle, do you need to measure/label every side?
- How many different ways can you find the perimeter of this rectangle?

## Possible sentence stems

- \_\_\_\_\_ cm + \_\_\_\_\_ cm + \_\_\_\_\_ cm + \_\_\_\_\_ cm = \_\_\_\_\_ cm
- $2 \times$  \_\_\_\_\_ cm +  $2 \times$  \_\_\_\_\_ cm = \_\_\_\_\_ cm
- $2 \times$  (\_\_\_\_\_ cm + \_\_\_\_\_ cm) = \_\_\_\_\_ cm

## National Curriculum links

- Measure and calculate the perimeter of a rectilinear figure (including squares) in centimetres and metres

# Perimeter of a rectangle

## Key learning

- Work out the perimeters of the rectangles.

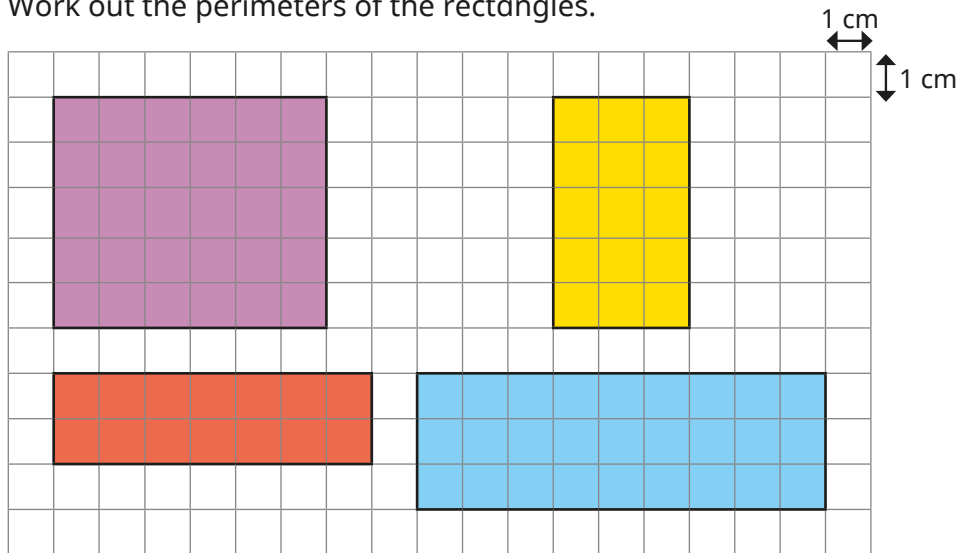

- Work out the perimeter of the rectangle.

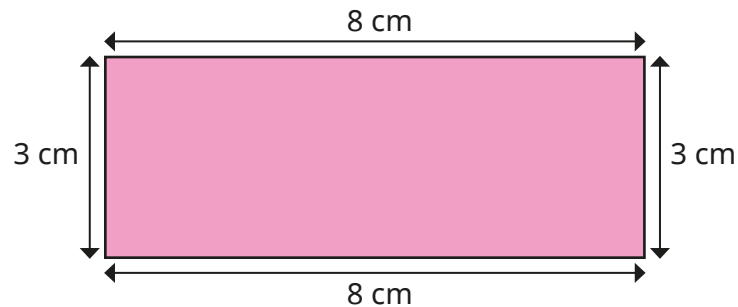

How many different ways can you work out the perimeter?

- Mo and Eva are working out the perimeter of the rectangle.

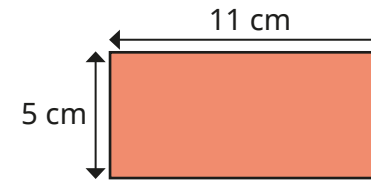

**Mo**

$$5 \text{ cm} + 11 \text{ cm} = 16 \text{ cm}$$

$$16 \text{ cm} \times 2 = 32 \text{ cm}$$

**Eva**

$$5 \text{ cm} + 5 \text{ cm} = 10 \text{ cm}$$

$$11 \text{ cm} + 11 \text{ cm} = 22 \text{ cm}$$

$$10 + 22 = 32 \text{ cm}$$

What is the same and what is different about their methods?

- Work out the perimeters of the rectangles.

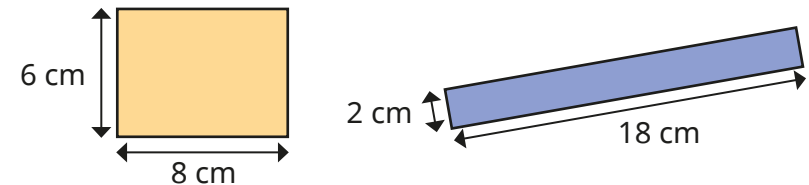

Compare methods with a partner.

- The perimeter of a rectangle is 30 cm. The length of the rectangle is 11 cm. What is the width of the rectangle?

# Perimeter of a rectangle

## Reasoning and problem solving

Whitney makes a rectangle using pencils.

Each pencil is 11 cm long.

What is the perimeter of the rectangle?

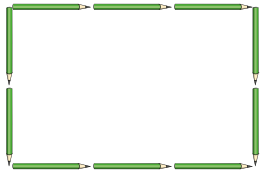

110 cm

Mo is describing a square.

Use the clues to work out the perimeter of the square.

- The perimeter is a 2-digit even number less than 50
- The sum of the digits of the perimeter is 9
- The side length is a whole number of metres.

36 m

Is the statement always true, sometimes true or never true?

When the sides of a rectangle are all odd numbers, the perimeter is an even number.

Explain your answer.

always true

Mrs Trent is working out the perimeter of her garden.

- The length of the garden is double its width.
- The width of the garden is a multiple of 3
- The perimeter of the garden is less than 40

What could the length, width and perimeter of Mrs Trent's garden be?

Find all the possible answers.

6 m long,  
3 m wide,  
perimeter 18 m  
  
12 m long,  
6 m wide,  
perimeter 36 m



# Perimeter of rectilinear shapes

## Notes and guidance

This small step continues to build children's understanding of perimeter by exploring more rectilinear shapes, both with and without grids.

Children know that a rectilinear shape has straight lines that meet at right angles. In this step, it is useful for children to measure the perimeter practically before they find the perimeter of a shape on a grid or from a shape with all side lengths labelled. When calculating, children should mark the sides they have already counted to avoid duplication or omission.

At this stage, children do not need to calculate unknown side lengths as this will be covered in the next step.

## Things to look out for

- Children may make arithmetical errors when adding the side lengths.
- Children may omit sides or count them more than once.
- When working on a grid, children may count the number of squares around the shape rather than the side lengths.
- Children may add the side lengths and double them, as they did when calculating the perimeters of rectangles.

## Key questions

- What is a rectilinear shape?
- How many sides does the shape have?
- Are any of the sides equal in length?
- What strategies can you use to find the perimeter?
- How can you be sure you have included all the sides?
- How can you check your answer?
- How many rectilinear shapes can you draw with a perimeter of \_\_\_\_\_ cm?

## Possible sentence stems

- The calculation I need to do to work out the perimeter is ...
- The shape has \_\_\_\_\_ sides, so I need to add together \_\_\_\_\_ lengths to find the perimeter.
- The perimeter of the shape is \_\_\_\_\_ mm/cm/m.

## National Curriculum links

- Measure and calculate the perimeter of a rectilinear figure (including squares) in centimetres and metres

# Perimeter of rectilinear shapes

## Key learning

- Annie has made some shapes using lolly sticks.

How many lolly sticks have been used to make each shape?

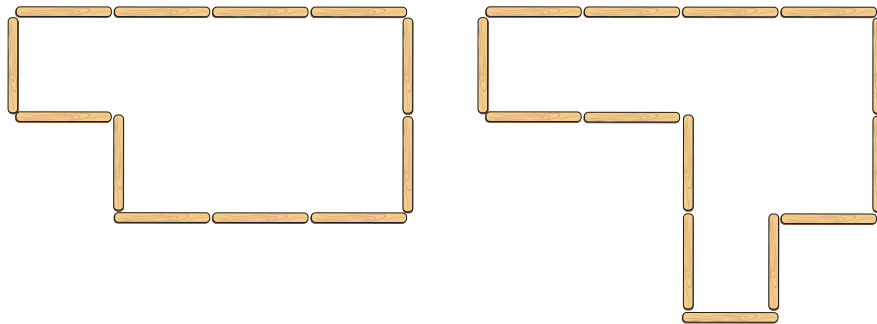

Which shape has the greater perimeter?

Use 12 lolly sticks to create different rectilinear shapes.

- Work out the perimeters of the shapes.

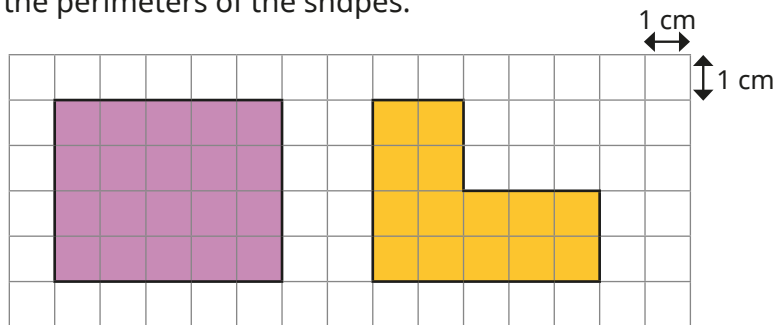

What do you notice?

- Work out the perimeters of the shapes.

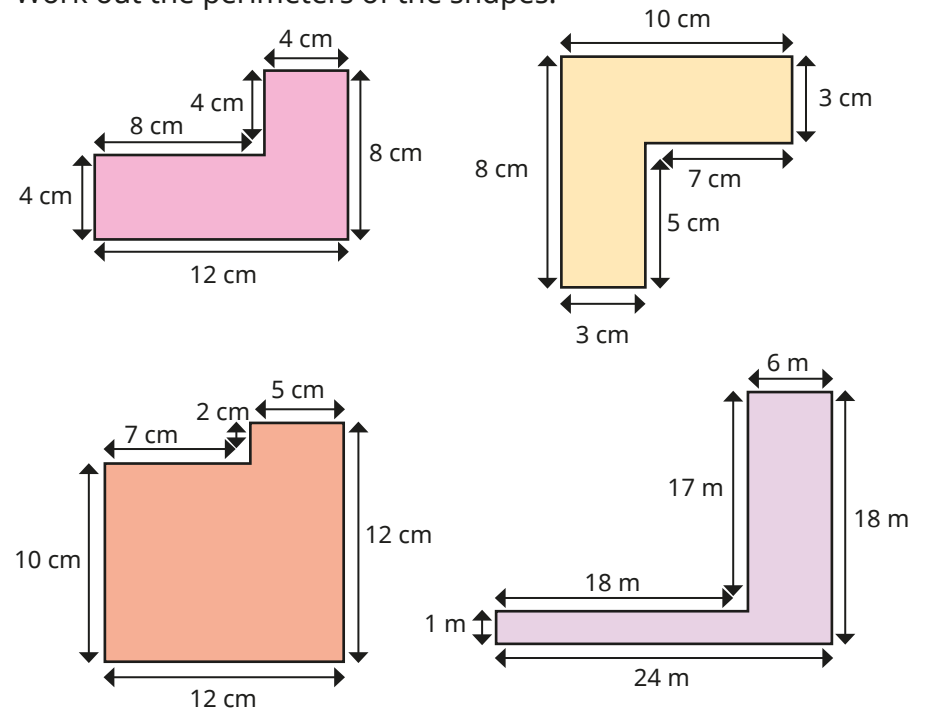

- How many rectilinear shapes can you draw that have a perimeter of 24 cm?

How many sides do they each have?

What is the length of the longest side of each of your shapes?

What is the length of the shortest side of each of your shapes?

# Perimeter of rectilinear shapes

## Reasoning and problem solving



Tiny has measured the lengths of the sides of the shape.

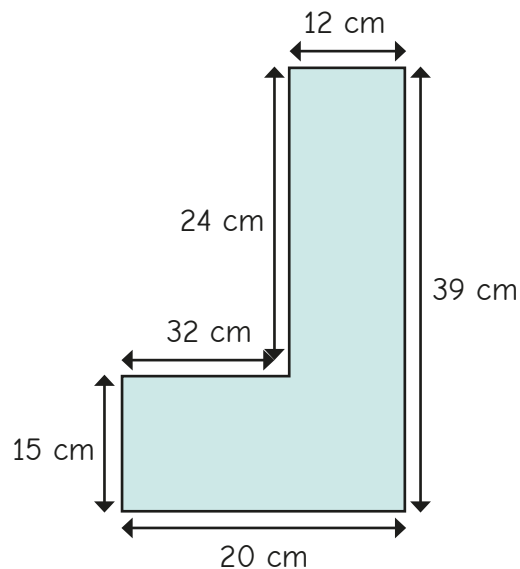

The side labelled 20 cm is longer than the side labelled 32 cm.

How can you tell that Tiny has made a mistake?

Ron has drawn some letters on a grid.  
Which letter has the greater perimeter?

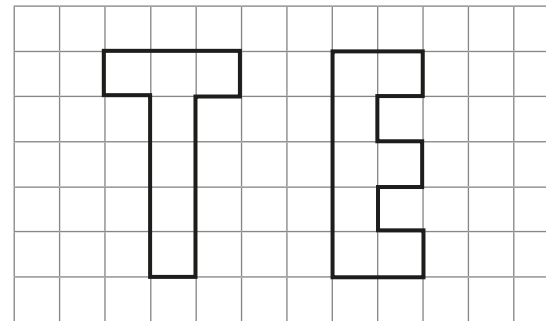

Explore other letters that can be drawn as rectilinear shapes.

Put them in order from smallest to greatest perimeter.

Compare answers with a partner.



E  
E = 18 units,  
T = 16 units

multiple possible answers

# Find missing lengths in rectilinear shapes

## Notes and guidance

In this small step, children continue to look at rectilinear shapes, focusing on finding missing side lengths.

Children explore the relationship between the sides of a rectilinear shape, rather than finding the perimeter. They start by using addition to find the missing side lengths, then using subtraction and finally using both operations to find more than one missing side length. Part-whole models may be useful here.

Children may find it helpful to draw the shapes and measure them, enabling them to notice that the opposite sides of the shapes are related. They could cut pieces of string or thin strips of paper to see which parts of a side correspond to another side.

### Things to look out for

- Children may need support to notice the relationships between the sides.
- Children may use the wrong operation to find the missing side length, for example adding two sides instead of subtracting them.
- The words “horizontal” and “vertical” may be unfamiliar.

## Key questions

- What lengths do you know?  
What lengths do you need to find out?
- What is the total horizontal length of the shape?  
Which sides add together to give the same total?
- What is the total vertical length of the shape?  
Which sides add together to give the same total?
- Do you need to add or subtract to find the missing length?  
How do you know?
- Are you finding a part or a whole?

## Possible sentence stems

- \_\_\_\_\_ + \_\_\_\_\_ = \_\_\_\_\_
- \_\_\_\_\_ = \_\_\_\_\_ - \_\_\_\_\_
- The missing side length is \_\_\_\_\_ because ...

## National Curriculum links

- Measure and calculate the perimeter of a rectilinear figure (including squares) in centimetres and metres

# Find missing lengths in rectilinear shapes

## Key learning

- Find the missing lengths on the shapes.

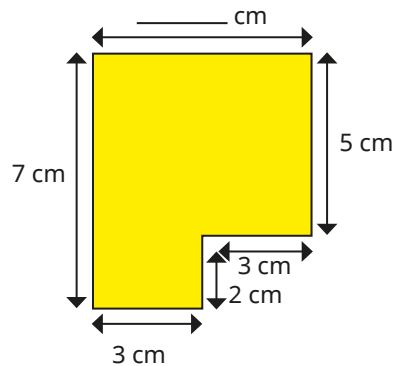

$$3 \text{ cm} + 3 \text{ cm} = \text{_____ cm}$$

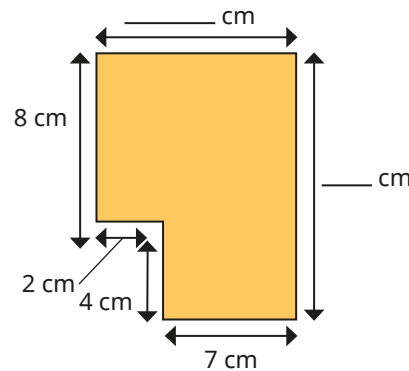

$$7 \text{ cm} + 2 \text{ cm} = \text{_____ cm}$$

$$8 \text{ cm} + 4 \text{ cm} = \text{_____ cm}$$

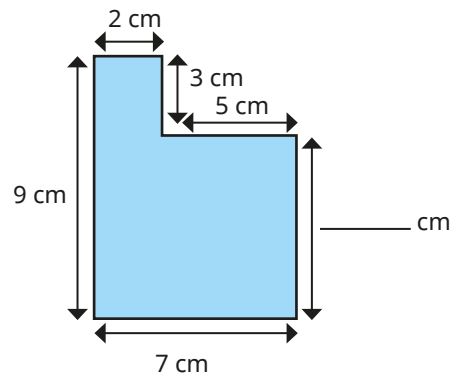

$$9 \text{ cm} - 3 \text{ cm} = \text{_____ cm}$$

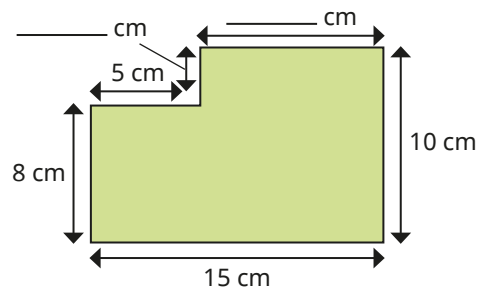

$$15 \text{ cm} - 5 \text{ cm} = \text{_____ cm}$$

$$10 \text{ cm} - 8 \text{ cm} = \text{_____ cm}$$

- Find the missing lengths on the shapes.

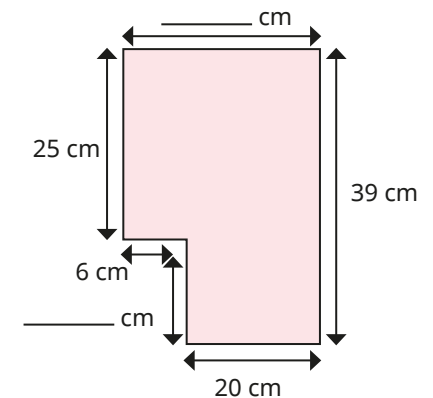
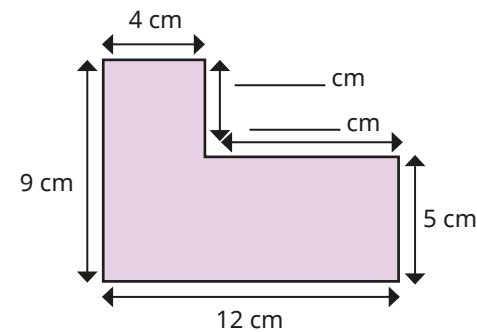

- Alex has made a shape with three identical rectangles.

Each rectangle is 20 cm long and 10 cm wide.

Work out the lengths of all eight sides of Alex's shape.

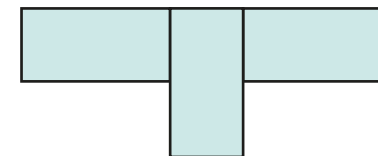



How would your answers change if the rectangles were 24 cm long and 12 cm wide?

# Find missing lengths in rectilinear shapes

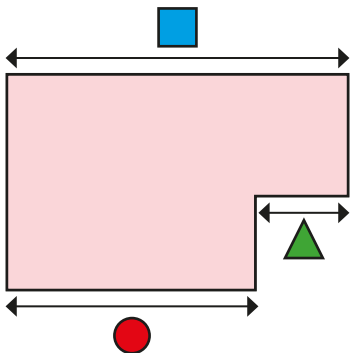
## Reasoning and problem solving



The length of side  is equal to the total length of side  and side .

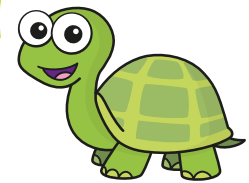

Is Tiny correct?  
Explain your answer.

Yes

Mr Lee wants to wallpaper this room.

He knows the lengths of some walls, but not all of them.

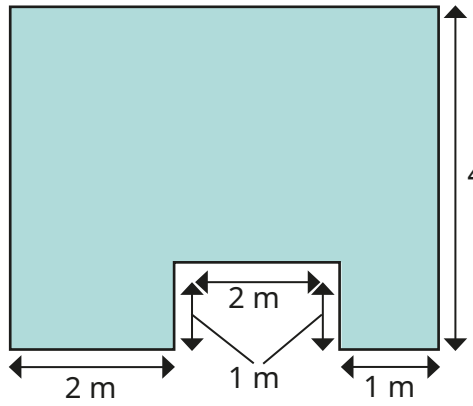

left side: 4 m  
top side: 5 m

Explain how Mr Lee can work out the unknown lengths.  
What are the unknown lengths?

# Calculate the perimeter of rectilinear shapes

## Notes and guidance

Building on the previous step, children move on to calculating the perimeter of rectilinear shapes where they first need to find the missing length(s). This could involve addition or subtraction depending on the information given in the question.

Children identify equivalent sides and, after calculating any unknown lengths, annotate the shape, ensuring that every side is labelled. This helps to prevent errors or omissions when calculating the perimeter.

Children also work backwards from a given perimeter to work out an unknown side length.

## Things to look out for

- Children may need support to identify equivalent sides.
- Children may use the wrong operation to find the missing length. For example, they may add together two sides rather than subtract them.
- When finding the perimeter of a complex rectilinear shape, children may miss a side when adding, or add the same side twice.

## Key questions

- What lengths do you know?  
What lengths do you need to find out?
- What is the total horizontal/vertical length of the shape?  
Which sides add together to give the same total?
- Where is the missing length on the shape?
- How many missing lengths are there on the shape?
- Do you need to add or subtract to find the missing length?  
How do you know?
- Are you finding a part or a whole?

## Possible sentence stems

- The side measuring \_\_\_\_\_ and the side measuring \_\_\_\_\_ are equal to the side measuring \_\_\_\_\_
- To work out the unknown length, I need to \_\_\_\_\_ because ...
- There are \_\_\_\_\_ sides, so I need to add together \_\_\_\_\_ lengths to find the perimeter.

## National Curriculum links

- Measure and calculate the perimeter of a rectilinear figure (including squares) in centimetres and metres

# Calculate the perimeter of rectilinear shapes

## Key learning

- Work out the perimeters of the rectilinear shapes.

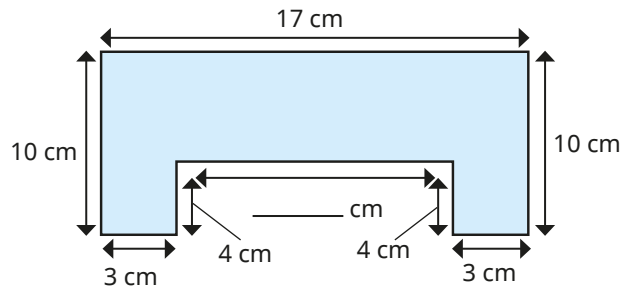
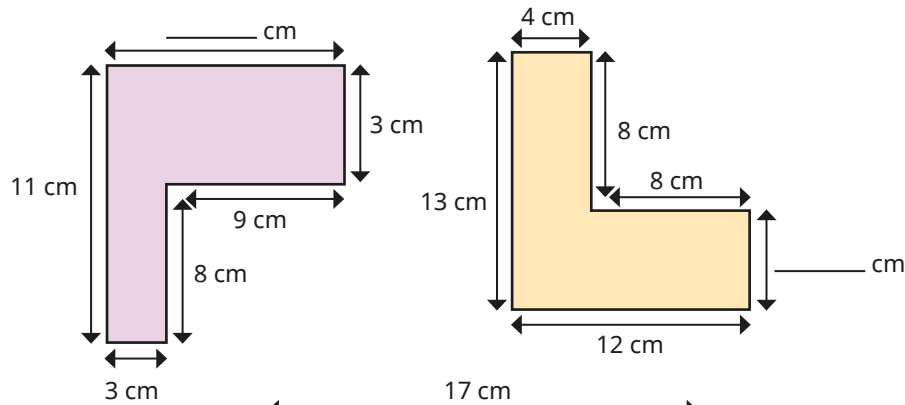

- Find the unknown lengths and the perimeter of the rectilinear shape.

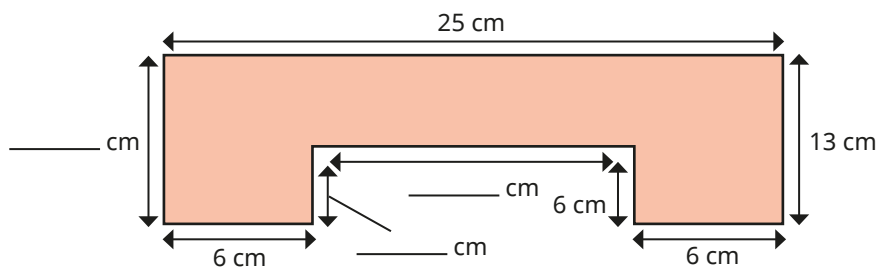

- Work out the perimeter of this shape.

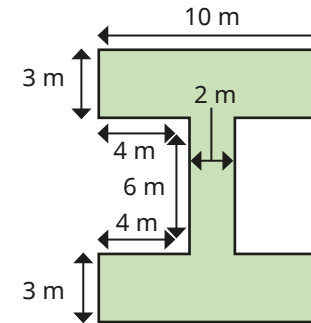

How did you work out the perimeter?

Compare methods with a partner.

- The perimeter of this rectilinear shape is 44 cm.

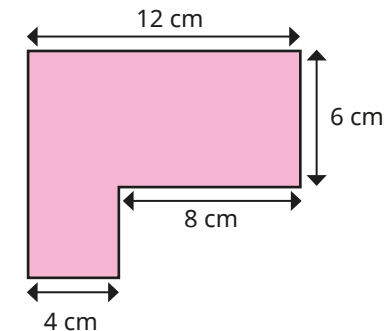

Work out the unknown lengths.



# Calculate the perimeter of rectilinear shapes

## Reasoning and problem solving

The length of one side of a square is 12 cm.

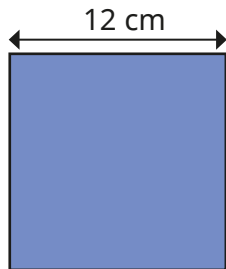

The square is cut in half to make two rectangles.

The two halves are put together to make this shape.

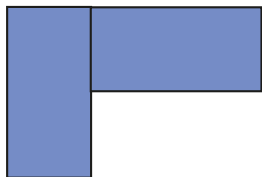

What is the perimeter of the new shape?

How did you work it out?

60 cm

△, ▲, ● and ■ all represent whole numbers.

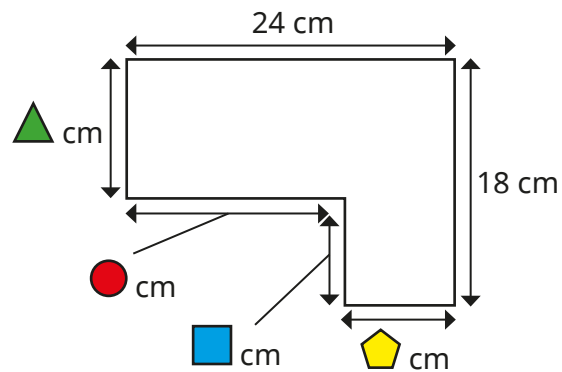

What could the value of ▲ and ■ be?

What could the value of ● and ▲ be?

Using these values, what is the perimeter of the rectilinear shape?

Experiment for other values.

What do you notice?

multiple possible answers, e.g.

▲ = 13 and ■ = 5

● = 18 and ▲ = 6

The perimeter is 84 cm.

# Perimeter of regular polygons

## Notes and guidance

In this small step, children are introduced to the term “regular polygon” for the first time. Explain that, in a regular polygon, all sides are equal in length and the angles are equal in size. For this step, children only need to understand that a regular polygon has equal side lengths, as they will not be exposed to shapes that have the same side lengths with different angles.

Children use the equality of sides to calculate the perimeter of regular polygons by making links with repeated addition and/or multiplication facts. Similarly, they use division to find the length of one side of a regular polygon when given its perimeter.

Children may need reminding that a polygon is a flat shape with straight sides.

### Things to look out for

- Children may need support to learn the names of different polygons and the number of sides they have.
- Children need to be secure with multiplication and division facts.
- Children may misunderstand the word “regular” and think that, for example, a rectangle is regular.

## Key questions

- What is a polygon?
- How do you know if a polygon is regular?
- If one side is \_\_\_\_\_ cm, what is the length of each of the other sides of the shape? How can you find the perimeter?
- Is an equilateral triangle a regular shape?
- Is a rectangle a regular shape?
- If you know the perimeter of a regular polygon, how can you work out the length of each side?

## Possible sentence stems

- Each side is \_\_\_\_\_ cm.  
There are \_\_\_\_\_ sides, so the perimeter of the polygon is \_\_\_\_\_ × \_\_\_\_\_ cm = \_\_\_\_\_ cm.
- \_\_\_\_\_ cm + \_\_\_\_\_ cm + \_\_\_\_\_ cm = 3 × \_\_\_\_\_ cm  
= \_\_\_\_\_ cm

## National Curriculum links

- This small step is not taken from the Year 4 National Curriculum. It is included to take into account the non-statutory DfE Ready to Progress guidance.

# Perimeter of regular polygons

## Key learning

- A polygon is regular if all its sides are equal in length and all its angles are equal in size.

Which of these polygons are regular?

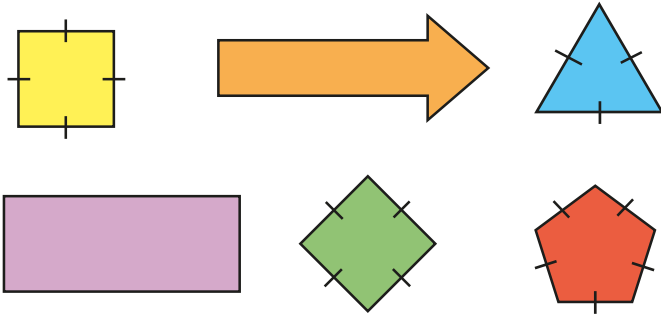

- Work out the perimeters of the regular polygons.

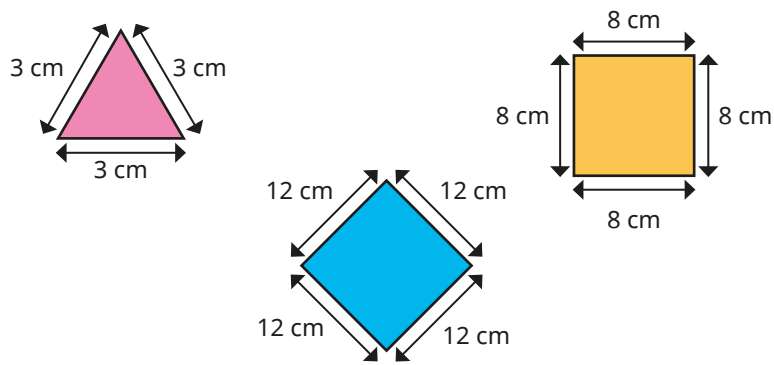

How did you work out the perimeters?

- Tommy has found a rule to work out the perimeter of a regular polygon.

$$\text{perimeter} = \text{number of sides} \times \text{length of one side}$$

Use this rule to work out the perimeters of these regular polygons.

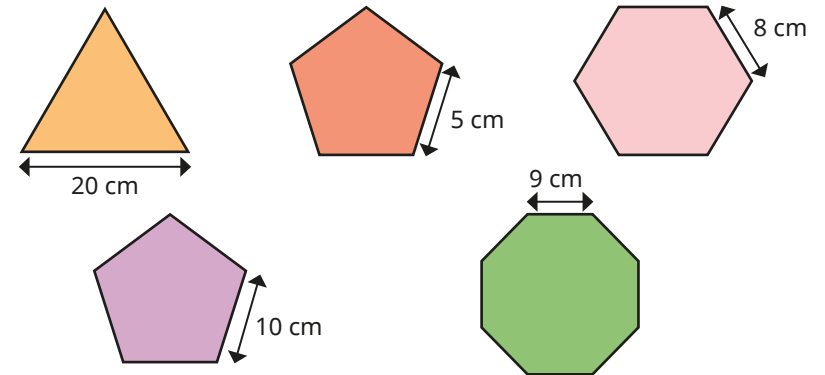

- Which has the greater perimeter?

a square with a side length of 12 cm

a regular octagon with a side length of 6 cm

# Perimeter of regular polygons

## Reasoning and problem solving

The perimeter of an equilateral triangle is 45 cm.

Work out the length of each side of the triangle.

15 cm

The perimeter of a regular pentagon is 60 cm.

Work out the length of each side of the pentagon.

12 cm

Filip has drawn some regular polygons.

Each polygon has a perimeter of 40 cm.

All the sides measure whole numbers of centimetres.

How many sides might the polygon have?

Compare answers with a partner.

4, 5, 8, 10, 20, 40

Dani has joined together three regular decagons to make a new shape.

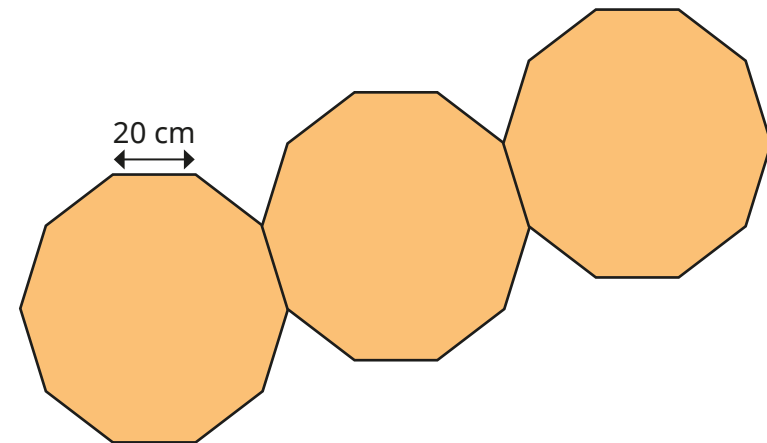

What is the perimeter of the new shape?

How did you work it out?

Talk about it with a partner.

520 cm

# Perimeter of polygons

## Notes and guidance

In this small step, children learn the word “irregular” to describe polygons that are not regular. Show children a range of irregular shapes to help them to identify that either the lengths or angles, or both, are not all equal. In this step, children are exposed to examples of polygons in which the lengths are equal but angles are not, and this is an important discussion point.

Children continue to add the side lengths together to find the perimeter. Encourage children to use number bonds to add related sides (for example,  $4\text{ cm} + 6\text{ cm} = 10\text{ cm}$ ) when working out the perimeter, as this will make calculating more efficient. They also use symmetry and properties of shapes to label lengths that are not given to help them calculate perimeters of shapes that are partially labelled.

Children should still label and mark sides as they are working out perimeters to help avoid errors.

## Things to look out for

- Children may try to measure unknown sides rather than use the given information to work out the lengths.
- When finding the perimeter of a more complex shape, children may omit some of the sides, or count them more than once.

## Key questions

- What is the difference between a regular and an irregular polygon?
- Is the shape irregular? How do you know?
- How can you work out the perimeter of the shape?
- Are any of the sides the same length?
- What is the length of each side?
- How can you work out the perimeter more efficiently?
- If the shape is symmetrical, how can this help you to work out some of the missing side lengths?

## Possible sentence stems

- The shape is regular/irregular because ...
- There are \_\_\_\_\_ sides, so I need to add together \_\_\_\_\_ lengths to work out the perimeter.
- The calculation I need to do to work out the perimeter is ...

## National Curriculum links

- This small step is not taken from the Year 4 National Curriculum. It is included to take into account the non-statutory DfE Ready to Progress guidance.

# Perimeter of polygons

## Key learning

- Mo uses lolly sticks to make some polygons. Each stick is 6 cm long.

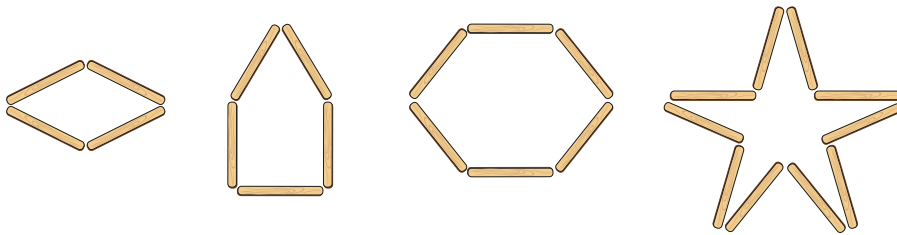

Work out the perimeters of the shapes.

Are any of the shapes regular? How can you tell?

- Work out the perimeters of these hexagons.

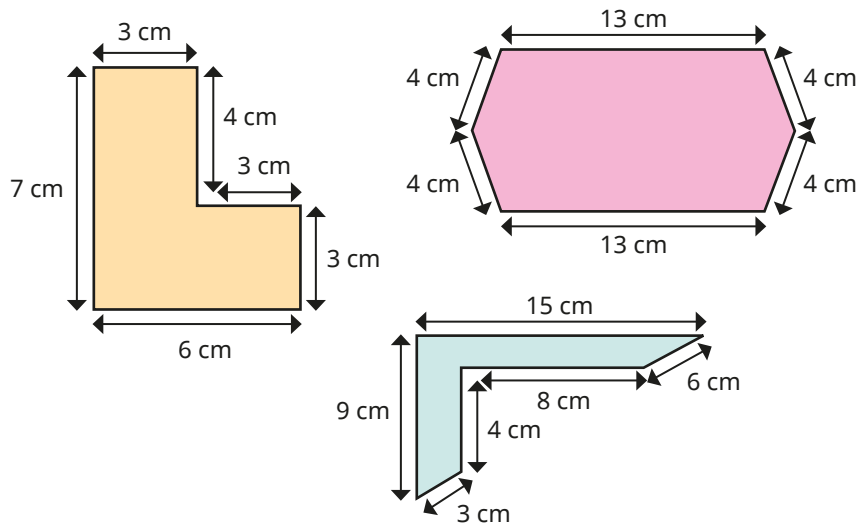

- All the shapes have one line of symmetry. Work out the perimeters of the shapes.

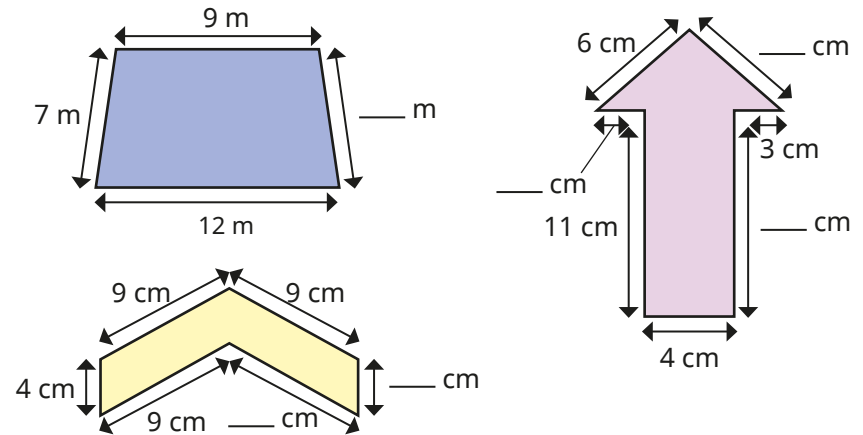

- The perimeter of this triangle is 19 cm. Work out the unknown length.

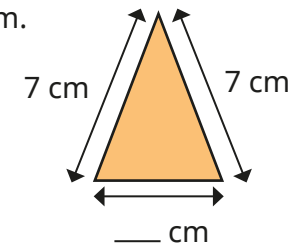

- The perimeter of a rectangle is 22 cm. The length of the rectangle is 8 cm. Work out the width of the rectangle.

# Perimeter of polygons

## Reasoning and problem solving

I have enough information to work out the perimeter of this shape.

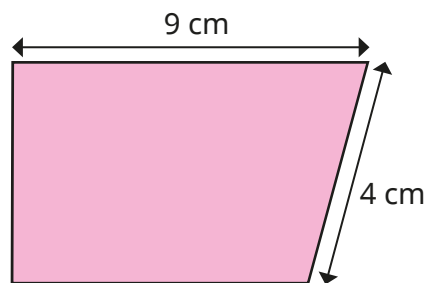
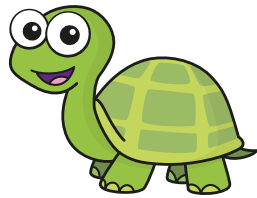

Do you agree with Tiny?  
Explain your answer.

No

The perimeter of a rectangle is 18 cm.

Each side is a whole number of centimetres.

The side marked is longer than the side marked .

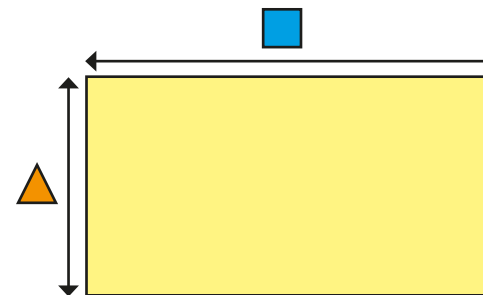

- = 8, = 1
- = 7, = 2
- = 6, = 3
- = 5, = 4

What could be the lengths of and .

Find as many possibilities as you can.

What do you notice?

Spring Block 3

# Fractions



## Small steps

Step 1

Understand the whole

Step 2

Count beyond 1

Step 3

Partition a mixed number

Step 4

Number lines with mixed numbers

Step 5

Compare and order mixed numbers

Step 6

Understand improper fractions

Step 7

Convert mixed numbers to improper fractions

Step 8

Convert improper fractions to mixed numbers



## Small steps

Step 9

Equivalent fractions on a number line

Step 10

Equivalent fraction families

Step 11

Add two or more fractions

Step 12

Add fractions and mixed numbers

Step 13

Subtract two fractions

Step 14

Subtract from whole amounts

Step 15

Subtract from mixed numbers



# Understand the whole

## Notes and guidance

Children begin this block by understanding the whole. They covered this in Year 3, but may need to recap the part-whole relationship of fractions.

Children use diagrams to identify how many equal parts a shape has been split into and move on to thinking about how many more parts are needed to make the whole. They use the denominator to identify how many equal parts a whole has been divided into. For example, for the fraction  $\frac{3}{7}$ , the whole has been split into 7 equal parts because the denominator is 7. Children explain whether a fraction is a small (for example,  $\frac{1}{10}$ ) or large (for example,  $\frac{9}{10}$ ) part of the whole.

The learning from this step will be built upon when looking at fractions greater than 1 and also decimals later in the year.

### Things to look out for

- Children may not be able to identify or explain whether a fraction is a large or small part of the whole.
- When trying to identify how many equal parts the whole has been divided into, some children may be reliant on diagrams rather than using the denominator.

## Key questions

- Has the whole been divided into equal parts?  
How do you know?
- In this diagram, how many equal parts has the whole been divided into?
- How many equal parts has the whole been divided into for  $\frac{1}{5}$ ?
- Is this a large or small part of the whole? How do you know?
- How many more parts are needed to make the whole?  
What fraction would this be?

## Possible sentence stems

- The whole has been divided into \_\_\_\_\_ equal parts.
- \_\_\_\_\_ has been shaded.  
To make 1 whole, I need to shade \_\_\_\_\_ equal parts.  
This is \_\_\_\_\_

## National Curriculum links

- Recognise and use fractions as numbers: unit fractions and non-unit fractions with small denominators (Y3)

# Understand the whole

## Key learning

- Which shapes have been split into equal parts?

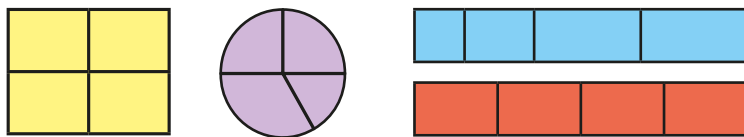

- Complete the sentences for each shape.

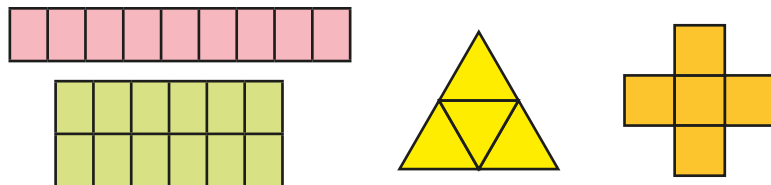

The whole is divided into \_\_\_\_\_ equal parts.

Each part is worth  $\frac{1}{\square}$

- What fraction of each diagram is shaded in each colour?



What fraction of each diagram represents the whole?

- Shade the shapes to make one whole.

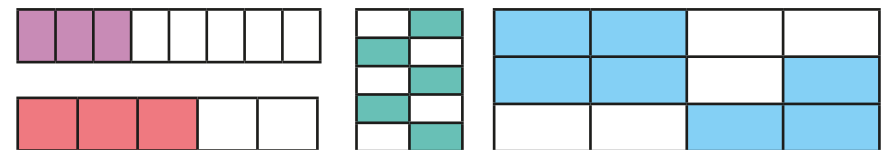

Complete the sentences for each diagram.

To make 1 whole, I shaded \_\_\_\_\_ equal parts.

The fraction I shaded was \_\_\_\_\_

- Complete the additions.

$$\triangleright \frac{3}{4} + \frac{\square}{\square} = 1$$

$$\triangleright \frac{3}{7} + \frac{\square}{\square} = 1$$

$$\triangleright 1 = \frac{\square}{\square} + \frac{3}{10}$$

- Use the information in the table to draw each whole.

1 part	Number of parts in the whole
	5
	4
	3

Is there more than one answer?

# Understand the whole

## Reasoning and problem solving

Sort the fractions into the table.

$\frac{3}{100}$	$\frac{3}{4}$	$\frac{3}{5}$
-----------------	---------------	---------------

$\frac{3}{50}$	$\frac{17}{20}$	$\frac{7}{20}$
----------------	-----------------	----------------

Fractions that are a small part of the whole	Fractions that are a large part of the whole

Explain your choices.

What do you notice about the fractions?

small:  $\frac{3}{100}, \frac{3}{50}, \frac{7}{20}$

large:  $\frac{3}{4}, \frac{3}{5}, \frac{17}{20}$



If I split a shape into 4 parts, I have split it into quarters.

Is Tiny's statement always true, sometimes true or never true?

How do you know?



sometimes true

Filip splits a piece of ribbon into equal parts.

Here is part of his ribbon.

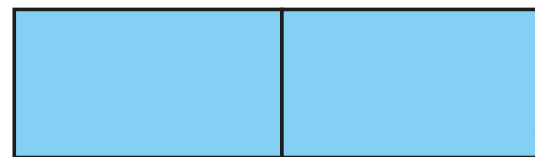

What fraction of the ribbon could the other part be?



multiple possible answers, with the denominator 2 greater than the numerator, e.g.

$$\frac{2}{4}, \frac{5}{7}, \frac{98}{100}$$

# Count beyond 1

## Notes and guidance

In this small step, children build on their knowledge of the whole to explore fractions greater than 1

In Year 3, children counted forwards and backwards in fractions within 1 and this is now extended to fractions greater than 1. Number lines are a useful representation, particularly alongside other pictorial representations such as bar models, to support children in counting in fractions. Children first count in unit fractions, using their knowledge that a fraction with the same numerator and denominator can be written as 1. Once comfortable counting forwards and backwards in unit fractions across whole number boundaries, they count in non-unit fractions.

In this step, children count in mixed numbers only, as improper fractions are covered later in the block. It is vital, therefore, that children are secure with the fact that when the numerator is equal to the denominator then the fraction is equivalent to 1

### Things to look out for

- Children may think that fractions must be less than 1
- When crossing a whole number, particularly when counting in non-unit fractions, children may miscount, either stopping at the whole number or ignoring it, for example  $\frac{4}{6}$ ,  $\frac{5}{6}$ ,  $1\frac{1}{6}$

## Key questions

- What fraction comes next after  $\frac{4}{7}$ ,  $\frac{5}{7}$ ,  $\frac{6}{7}$ ? How do you know?
- What fraction comes before \_\_\_\_\_? How do you know?
- What do you know about a fraction with the same numerator and denominator?
- What is 1 whole plus another  $\frac{1}{3}$ ?  
How could you draw that as a bar model?
- What is 3 and  $\frac{5}{5}$  the same as?
- What is the sequence counting forwards/backwards in?

## Possible sentence stems

- There are \_\_\_\_\_ \_\_\_\_\_s in 1
- The sequence is counting forwards/backwards in \_\_\_\_\_s.

## National Curriculum links

- This small step is not taken from the Year 4 National Curriculum. It is included to take into account the non-statutory DfE Ready to Progress guidance.

# Count beyond 1

## Key learning

- Fill in the missing numbers.

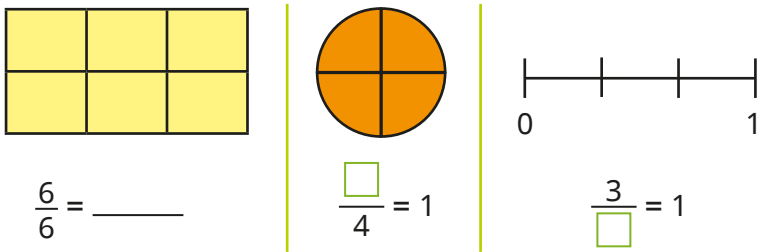

- Complete the number line, counting in sixths.

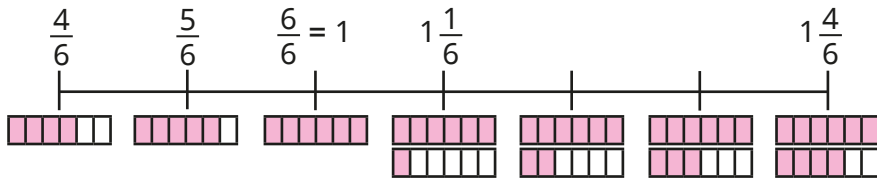

- Complete the number lines.

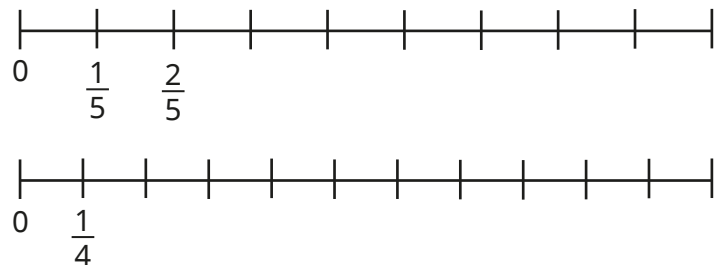

Complete the number lines.

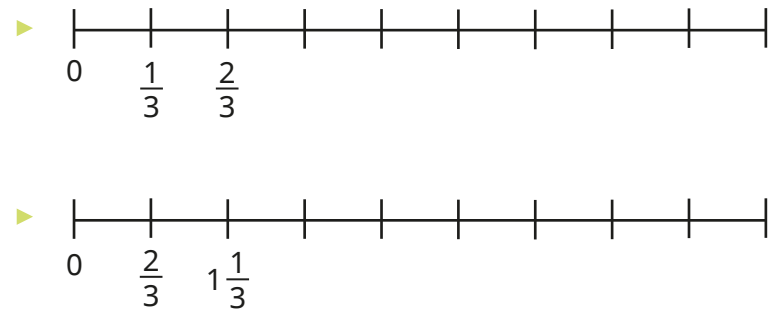

What is the same about the number lines?

What is different?

- Complete the number tracks.

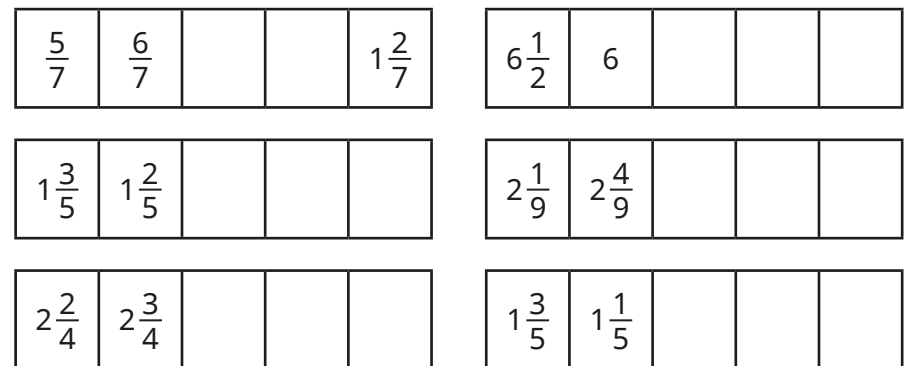

# Count beyond 1

## Reasoning and problem solving

Tiny is counting in fifths.

$\frac{1}{5}$	$\frac{2}{5}$	$\frac{3}{5}$	$\frac{4}{5}$	$\frac{5}{5}$
---------------	---------------	---------------	---------------	---------------

I cannot count any further, because fractions are always less than 1

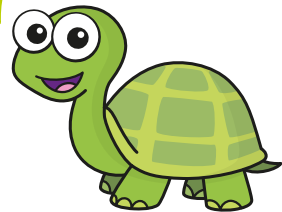

Do you agree with Tiny?  
Explain your answer.



No

Tommy, Whitney and Dexter are counting forwards and backwards.



Tommy

I am counting forwards in  $\frac{3}{7}$ s, starting at 0

I am counting forwards in  $\frac{4}{7}$ s, starting at 3



Whitney

$4\frac{5}{7}$



Dexter

I am counting backwards in  $\frac{2}{7}$ s, starting at 5

What number will all three children say?



# Partition a mixed number

## Notes and guidance

In this small step, children further develop their understanding of mixed numbers.

Children explore partitioning mixed numbers in different ways – a skill that will be vital for later steps in this block. The key focus is to ensure that children can confidently partition a mixed number into its whole and fractional parts. Part-whole models and bar models are key representations that allow children to see how a mixed number is being partitioned. Once confident with this form of partitioning, children partition a mixed number into a whole number and a mixed number (for example,  $3\frac{1}{4} = 2 + 1\frac{1}{4}$ ) or a mixed number and a fraction (for example,  $2\frac{3}{4} = 2\frac{1}{4} + \frac{2}{4}$ ).

### Things to look out for

- Children may mistake mixed numbers for improper fractions, particularly if their presentation is not clear, for example mistaking  $2\frac{3}{4}$  for  $\frac{23}{4}$
- Children need to be secure in the fact that all whole numbers can be made up of fractions, for example 1 whole =  $\frac{3}{3}$
- Children may be less confident with non-standard partitions, for example  $2\frac{3}{4} = 2\frac{1}{4} + \frac{2}{4}$

## Key questions

- What is a mixed number?
- What does each part of a mixed number represent?
- How many wholes are there in the mixed number \_\_\_\_\_?
- What is the fractional part of \_\_\_\_\_?
- How can you partition the mixed number into wholes and a fraction?
- How many other ways could you partition the mixed number?

## Possible sentence stems

- There are \_\_\_\_\_ wholes.
- There are  $\frac{\square}{\square}$
- The mixed number is \_\_\_\_\_  $\frac{\square}{\square}$
- \_\_\_\_\_ can be partitioned into \_\_\_\_\_ wholes and  $\frac{\square}{\square}$

## National Curriculum links

- This small step is not taken from the Year 4 National Curriculum. It is included to take into account the non-statutory DfE Ready to Progress guidance.

# Partition a mixed number

## Key learning

- What mixed number is shown in each diagram?

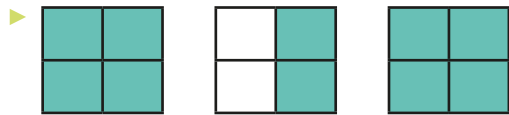
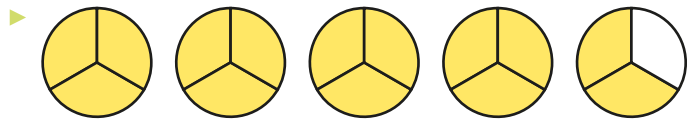

- Complete the part-whole models to show the wholes and fractions in the mixed numbers.

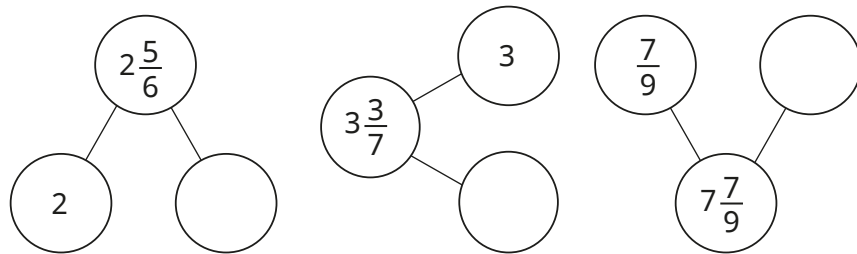

- Fill in the missing wholes and fractions.

▶  $4\frac{4}{5} = 4 + \frac{\square}{\square}$     ▶  $9\frac{5}{6} = \text{---} + \frac{5}{6}$     ▶  $6\frac{3}{10} = \text{---} + \frac{\square}{\square}$

- Use the diagram to help you complete the part-whole model.

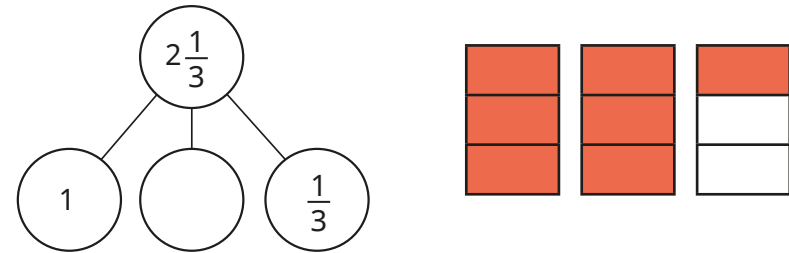

- Complete the part-whole models.

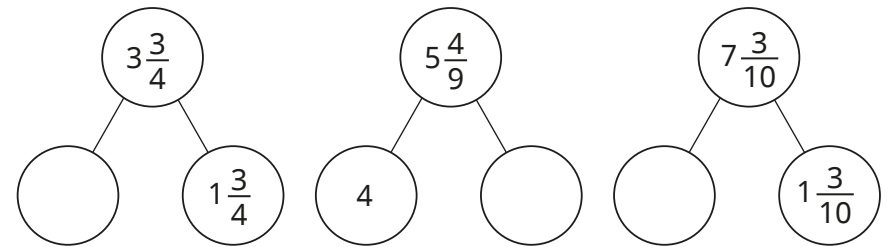

- Fill in the missing numbers.

▶  $4\frac{4}{5} = 4\frac{1}{5} + \frac{\square}{\square}$      $4\frac{4}{5} = 4\frac{2}{5} + \frac{\square}{\square}$      $4\frac{4}{5} = 4\frac{\square}{5} + \frac{1}{5}$   
 ▶  $2\frac{6}{7} = 2\frac{1}{7} + \frac{\square}{\square}$      $2\frac{6}{7} = 2\frac{3}{7} + \frac{\square}{\square}$      $2\frac{6}{7} = \text{---}\frac{4}{7} + \frac{\square}{\square}$

- Partition  $3\frac{2}{3}$  in as many different ways as you can.

# Partition a mixed number

## Reasoning and problem solving



Tiny has drawn some part-whole models of mixed numbers.

**A**

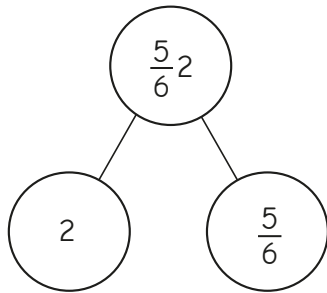

**B**

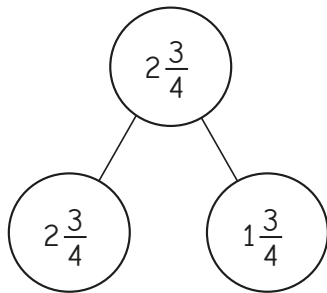

What mistakes has Tiny made?  
Correct the mistakes.



A:  $2\frac{5}{6}$  in whole

B: either

$2$  and  $\frac{3}{4}$

or

$1$  and  $1\frac{3}{4}$   
in the parts

Use the digit cards to complete the statements.



You can use each card once only.

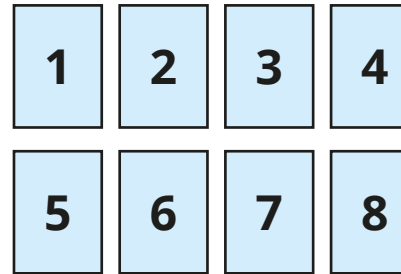

**A**

$$6\frac{7}{9} = \square + \square \frac{\square}{9}$$

**B**

$$6\frac{7}{9} = \square \frac{\square}{9} + \frac{\square}{9}$$

Find all the possible solutions.

four possible solutions for each:

A: 1, 5 and 7

5, 1 and 7

4, 2 and 7

2, 4 and 7

B: 6, 3 and 4

6, 4 and 3

6, 5 and 2

6, 2 and 5

# Number lines with mixed numbers

## Notes and guidance

In this small step, children build on their learning from Step 2 in this block, developing a deeper understanding of how mixed numbers are represented on a number line.

Children label the fractions on any given number line by identifying the number of intervals between each of the whole numbers. A common mistake is counting the number of divisions between consecutive integers. For example, a number line split into quarters has three dividing lines between each integer, so children may conclude that the number line is counting in thirds.

Children estimate the positions of mixed numbers on blank number lines. To support this, it is important that children understand which integer a mixed number is closer to, and the mixed number's relationship to the point halfway between the two wholes either side of it.

### Things to look out for

- Children may incorrectly count the number of intervals when working out what fraction the number line is counting in.
- Children may struggle to estimate on a number line if they are not secure in their knowledge of which whole a fraction is closer to.

## Key questions

- On the number line, how many intervals are there between these two consecutive whole numbers, \_\_\_\_\_ and \_\_\_\_\_?
- What is each interval worth on the number line?
- Is it more efficient to count on from the previous whole number or back from the next whole number when labelling \_\_\_\_\_?
- What is the whole number before and after \_\_\_\_\_?
- Is \_\_\_\_\_ closer to the previous or the next whole number? How do you know?

## Possible sentence stems

- The difference between the start and end of the number line is \_\_\_\_\_  
There are \_\_\_\_\_ intervals.  
Each interval is worth \_\_\_\_\_
- \_\_\_\_\_  $\frac{\square}{\square}$  is closer to \_\_\_\_\_ than \_\_\_\_\_

## National Curriculum links

- This small step is not taken from the Year 4 National Curriculum. It is included to take into account the non-statutory DfE Ready to Progress guidance.

# Number lines with mixed numbers

## Key learning

- What is the number line counting up in?

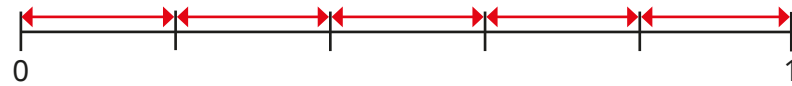

How do you know?

- Complete the number lines.

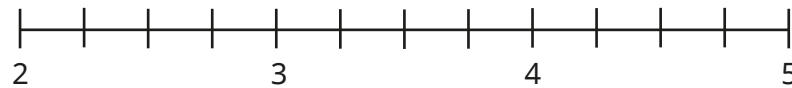
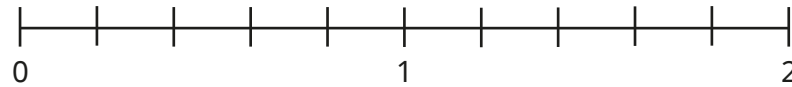

- What number is each arrow pointing to?



- Label the numbers on the number lines.

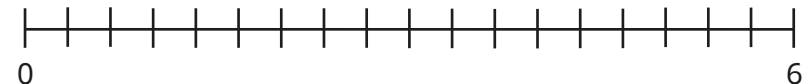
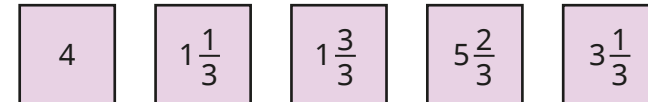
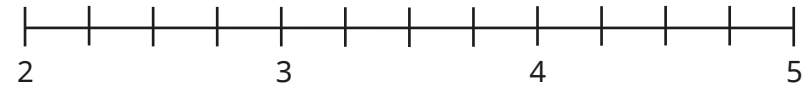

- Draw arrows to estimate the positions of the numbers on the number line.

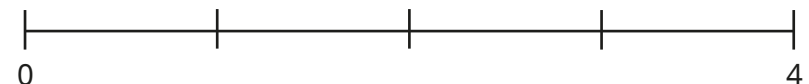
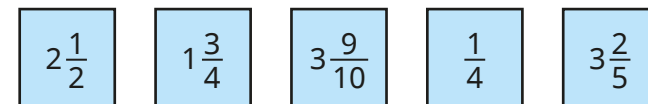

# Number lines with mixed numbers

## Reasoning and problem solving

Four children are labelling a blank number line that starts at zero.

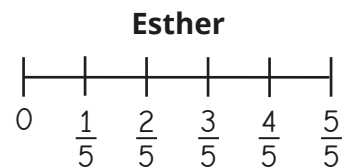
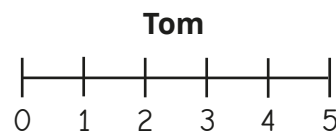
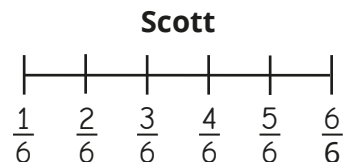
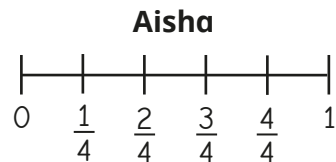

Who could be correct?

Who **cannot** be correct?

Talk about it with a partner.

Tom and Esther could be correct.

Aisha and Scott cannot be correct.

Draw arrows to estimate the position of  $2\frac{5}{6}$  on each number line.

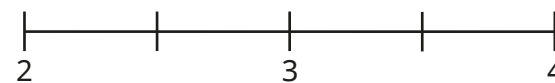
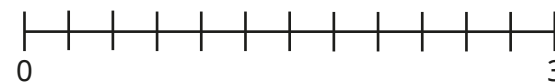
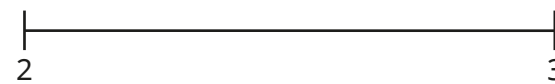
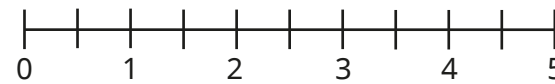

arrow in the correct place on each number line

Which number line did you find easiest/hardest to estimate on?

Why?

# Compare and order mixed numbers

## Notes and guidance

In this small step, children compare and order mixed numbers.

Before comparing mixed numbers, it may be appropriate to compare proper fractions to revise the understanding that, when the denominators are the same, the greater the numerator, the greater the fraction. Diagrams, bar models and number lines are effective tools when comparing fractions and mixed numbers.

Children compare mixed numbers where the whole number is different, recognising that the greater the whole number, the greater the mixed number. They then compare mixed numbers where the whole number is the same.

Once children are secure in comparing mixed numbers, they can move on to putting them in order.

### Things to look out for

- Children may not be secure in their understanding of how to compare proper fractions.
- Some children may compare the fraction first rather than the whole number, for example  $2\frac{4}{5} > 3\frac{1}{5}$  because  $\frac{4}{5} > \frac{1}{5}$
- If children are not confident in counting in fractions on a number line, they may find it difficult to place and compare fractions using this representation.

## Key questions

- How is comparing mixed numbers similar to comparing proper fractions? How is it different?
- Are the whole numbers the same?
- Which is the greater whole number?
- If the whole numbers are the same, what do you need to compare?
- Which is the greater fraction? How do you know?
- How do you know the mixed numbers are in order?

## Possible sentence stems

- First, I will compare the \_\_\_\_\_  
If they are the same, I will compare the \_\_\_\_\_
- If the denominator is the same, the \_\_\_\_\_ the numerator, the \_\_\_\_\_ the fraction.

## National Curriculum links

- This small step is not taken from the Year 4 National Curriculum. It is included to take into account the non-statutory DfE Ready to Progress guidance.

# Compare and order mixed numbers

## Key learning

- Which fraction is greater,  $2\frac{1}{6}$  or  $1\frac{5}{6}$ ?



How do you know?

- Draw bar models to help you compare the mixed numbers.

$$1\frac{3}{4} \bigcirc 2\frac{1}{4} \quad 4\frac{1}{2} \bigcirc 2\frac{1}{2} \quad 3\frac{3}{8} \bigcirc 1\frac{7}{9}$$

- Write  $<$  or  $>$  to compare the mixed numbers.

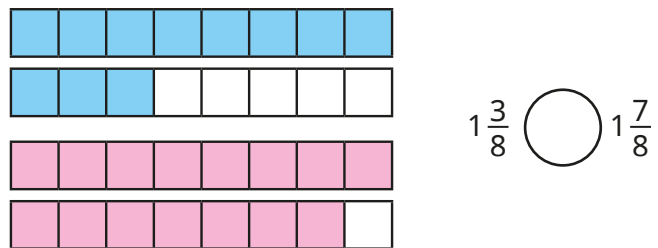

$$1\frac{3}{8} \bigcirc 1\frac{7}{8}$$

- Write  $<$  or  $>$  to compare the mixed numbers.

You can draw bar models to help you.

$$2\frac{1}{3} \bigcirc 2\frac{2}{3} \quad 2\frac{7}{10} \bigcirc 2\frac{1}{10}$$

- Use the number line to decide which mixed number is greater,  $1\frac{3}{4}$  or  $2\frac{1}{4}$

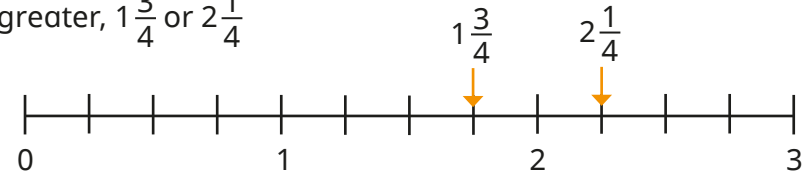

- Draw a number line to help compare the mixed numbers.

$$2\frac{2}{5} \bigcirc 2\frac{4}{5} \quad 1\frac{5}{7} \bigcirc 1\frac{2}{7}$$

- Mo is comparing mixed numbers.



I compare the wholes and then the fractions.

$$\begin{aligned} 1 &= 1 \\ \frac{3}{8} &< \frac{5}{8} \\ \text{So } 1\frac{3}{8} &< 1\frac{5}{8} \end{aligned}$$

Use Mo's method to compare the mixed numbers.

$$2\frac{3}{5} \bigcirc 2\frac{4}{5} \quad 1\frac{3}{5} \bigcirc 2\frac{3}{5} \quad 5\frac{7}{10} \bigcirc 5\frac{1}{10}$$

- Put the mixed numbers in order, starting with the smallest.

$$1\frac{3}{4}, 2\frac{3}{4}, 1\frac{1}{4}, 3\frac{3}{4}, 2\frac{1}{4}$$

$$15\frac{4}{7}, 15\frac{6}{7}, 15\frac{3}{7}, 16\frac{1}{7}, 15\frac{1}{7}$$



# Compare and order mixed numbers

## Reasoning and problem solving

Tiny is comparing mixed numbers.

$$3\frac{1}{10} < 2\frac{9}{10}$$

$2\frac{9}{10}$  is greater,  
because  $\frac{9}{10}$  is greater  
than  $\frac{1}{10}$

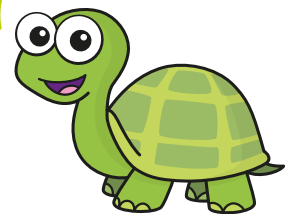

No

Do you agree with Tiny?  
Explain your answer.



Brett and Nijah are counting in fractions on a number line.



Brett starts at the arrow and counts forwards in quarters four times.

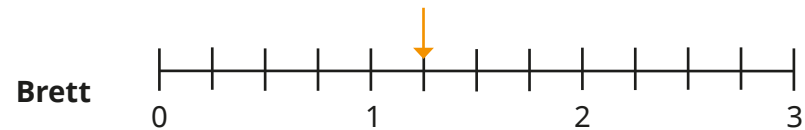

Nijah starts at the arrow and counts backwards in quarters four times.

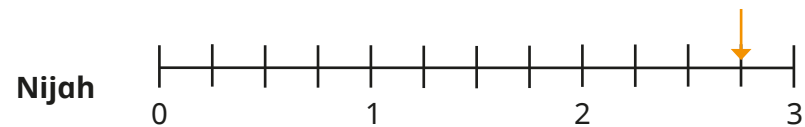

Who finishes on the greater number?

Brett

# Understand improper fractions

## Notes and guidance

Children should now be confident with the idea that fractions can be greater than 1 and have experienced these as mixed numbers. In this small step, they write them as improper fractions – a fraction where the numerator is greater than or equal to the denominator.

From previous learning, children know that when the numerator is equal to the denominator, the fraction is equal to 1 whole. That knowledge is extended to exploring other integers using knowledge of times-tables. For example, if children know that  $\frac{3}{3}$  is equal to 1, they can repeat groups of  $\frac{3}{3}$  to see that  $\frac{6}{3} = 2$  and  $\frac{9}{3} = 3$ . They then explore the improper fractions that lie between whole numbers. Bar models and number lines support this understanding.

At this point, children do not need to formally convert between improper fractions and mixed numbers, but they may begin to explore the relationships between them by plotting both on a number line.

## Things to look out for

- Children may not have seen fractions where the numerator is greater than the denominator before, which may have led to misconceptions about this not being possible.

## Key questions

- How many \_\_\_\_\_ (for example, thirds) are there in 1 whole?
- So how many \_\_\_\_\_ (for example, thirds) will there be in  $\frac{2}{3}$ / $\frac{4}{3}$  wholes?
- What do you think comes next in this count: 3 fifths, 4 fifths, 5 fifths?
- What is the same about mixed numbers and improper fractions? What is different?
- If there are 10 tenths in 1 whole, how many tenths are there in  $1\frac{1}{10}$ ?
- Which of these are improper fractions? How do you know?

## Possible sentence stems

- An improper fraction is a fraction where the numerator is \_\_\_\_\_ the denominator.
- There are \_\_\_\_\_ \_\_\_\_\_ in 1 whole, so there are \_\_\_\_\_ \_\_\_\_\_ in  $\frac{2}{3}$ / $\frac{4}{3}$  wholes.

## National Curriculum links

- This small step is not taken from the Year 4 National Curriculum. It is included to take into account the non-statutory DfE Ready to Progress guidance.

# Understand improper fractions

## Key learning

- Fill in the missing numbers.

▶   $\frac{3}{3} = \underline{\hspace{1cm}}$  whole

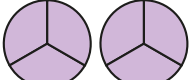
  $\frac{6}{3} = \underline{\hspace{1cm}}$  wholes

  $\frac{9}{3} = \underline{\hspace{1cm}}$  wholes

▶   $\frac{5}{5} = \underline{\hspace{1cm}}$  whole

  $\frac{10}{5} = \underline{\hspace{1cm}}$  wholes

  $\frac{\square}{5} = 3$  wholes

  $\frac{\square}{\square} = \underline{\hspace{1cm}}$  wholes

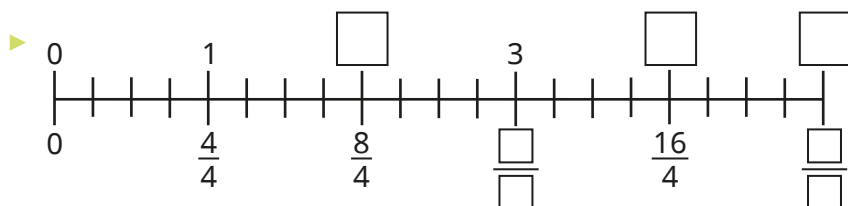

What do you notice?

- Fill in the missing numbers.

▶  $\frac{4}{2} = \underline{\hspace{1cm}}$       ▶  $\frac{10}{2} = \underline{\hspace{1cm}}$       ▶  $\frac{\square}{2} = 10$

▶  $\frac{30}{10} = \underline{\hspace{1cm}}$       ▶  $6 = \frac{\square}{10}$       ▶  $\frac{110}{10} = \underline{\hspace{1cm}}$

- What improper fractions are shown in the diagrams?



- Complete the number line by counting in improper fractions.

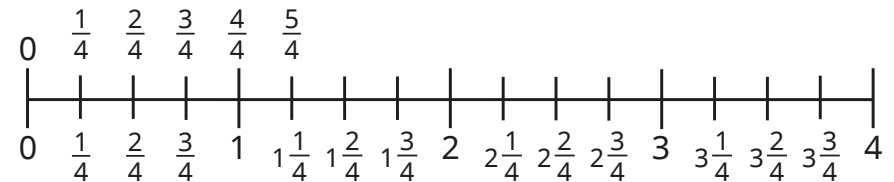

# Understand improper fractions

## Reasoning and problem solving

Tiny is talking about improper fractions.



If  $\frac{4}{4}$  is equal to 1,  
then  $\frac{5}{4} = 2$ ,  
 $\frac{6}{4} = 3$  and  $\frac{7}{4} = 4$

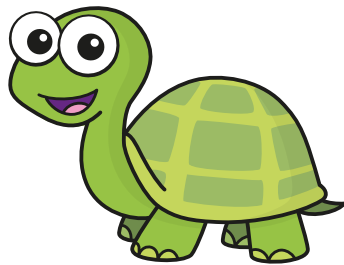

Do you agree with Tiny?  
Explain your reasons.



No

Use the digit cards to make as many improper fractions as you can.

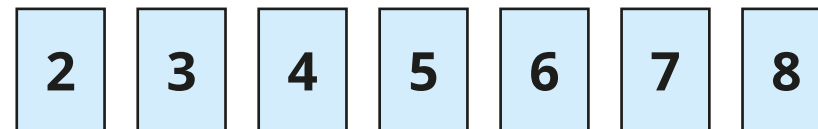

Which of the improper fractions are greater than 1 and less than 2?

Which of the improper fractions are greater than 2 and less than 3?

$\frac{3}{2}, \frac{4}{3}, \frac{5}{3}, \frac{5}{4}, \frac{6}{4}, \frac{7}{4}, \frac{6}{5}, \frac{7}{5}, \frac{8}{5}, \frac{7}{6}, \frac{8}{6}, \frac{8}{7}$

$\frac{5}{2}, \frac{7}{3}, \frac{8}{3}$

# Convert mixed numbers to improper fractions

## Notes and guidance

Having now been introduced to both mixed numbers and improper fractions, in this small step children convert a mixed number into an improper fraction.

At this stage, children explore this concept predominantly through the use of pictorial representations and concrete manipulatives such as interlocking cubes. Bar models and number lines are useful representations to allow children to see the links between mixed numbers and improper fractions.

Children use their times-tables knowledge to find the improper fraction equivalent to the integer part of a mixed number before adding on any remaining fractional parts.

### Things to look out for

- Fluent knowledge of times-tables will greatly support children in this step. Times-table grids could support children who are not yet fluent, allowing them to focus on the key learning of this step.
- Children may forget to add on the fractional part of the mixed number.
- Children may add the integer and the fractional part together, for example  $3\frac{4}{5} = \frac{7}{5}$

## Key questions

- What is the integer in the mixed number \_\_\_\_\_?
- What is the fractional part of the mixed number \_\_\_\_\_?
- How do you know if a fraction is improper?
- How many fifths are there in  $\frac{2}{3}$ / $\frac{1}{4}$  wholes? What do you notice?
- If there are 8 quarters in 2, how many more quarters do you need to add for the mixed number  $2\frac{3}{4}$ ?
- What do you notice about the improper fraction equivalences of  $2\frac{2}{9}$ ,  $2\frac{3}{9}$ ,  $2\frac{4}{9}$  /  $2\frac{2}{9}$ ,  $3\frac{2}{9}$ ,  $4\frac{2}{9}$ ?

## Possible sentence stems

- Each whole is worth \_\_\_\_\_

All the wholes are worth \_\_\_\_\_

Adding the fractional part means that altogether there are \_\_\_\_\_

## National Curriculum links

- This small step is not taken from the Year 4 National Curriculum. It is included to take into account the non-statutory DfE Ready to Progress guidance.

# Convert mixed numbers to improper fractions

## Key learning

- Each circle represents 1 whole.

What do the diagrams show?

Give your answers as an integer and as an improper fraction.

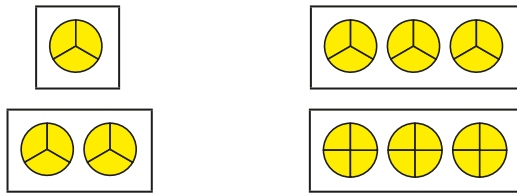

- Complete the sentences for each mixed number.

The integer in the mixed number is \_\_\_\_\_

This is equivalent to \_\_\_\_\_ quarters.

There are \_\_\_\_\_ more quarters.

\_\_\_\_\_ + \_\_\_\_\_ = \_\_\_\_\_

So the improper fraction is  $\frac{\square}{4}$

- ▶  $1\frac{1}{4}$
- ▶  $1\frac{2}{4}$
- ▶  $2\frac{2}{4}$
- ▶  $3\frac{3}{4}$

- Use the bar model to convert the mixed number to an improper fraction.

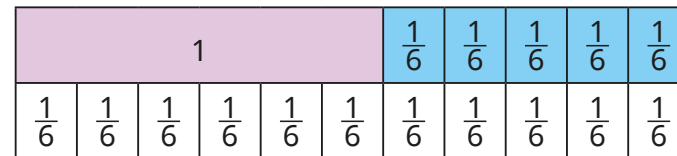

$$1\frac{5}{6} = \frac{\square}{6}$$

Draw a bar model to convert  $3\frac{2}{3}$  to an improper fraction.

- Use the number line to convert the mixed numbers to improper fractions.

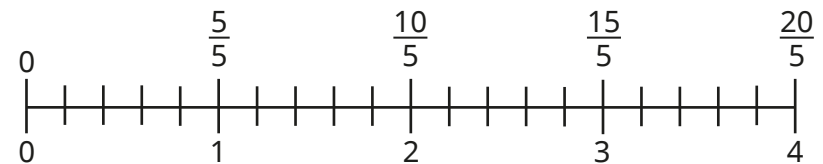
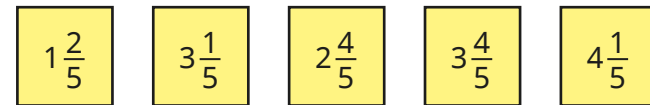

- Convert the mixed numbers to improper fractions.

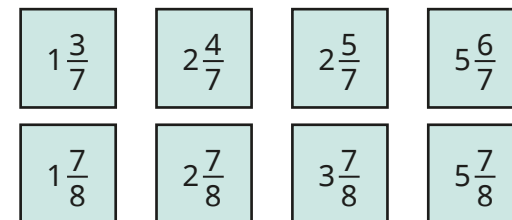

What do you notice?

# Convert mixed numbers to improper fractions

## Reasoning and problem solving

Teddy and Alex are converting  $3\frac{2}{4}$  into an improper fraction.



Teddy

3 plus 2 is equal to 5, so it is  $\frac{5}{4}$

3 lots of 2 is equal to 6, so it is  $\frac{6}{4}$



Alex

$$\frac{14}{4}$$

What mistake has each child made?

What is the correct answer?



Dora, Ron and Rosie each think of a different number.



Dora

My number has 2 wholes, 3 as a numerator and 8 as a denominator.

My number is greater than Rosie's, but less than Dora's.



Ron



Rosie

I have drawn my number.

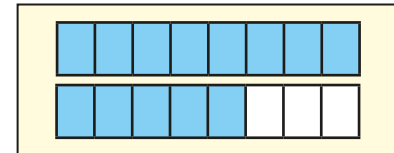

What number could Ron be thinking of?

Write each possible answer as both a mixed number and an improper fraction.

multiple possible answers e.g.  $1\frac{6}{8}$ ,  $\frac{14}{8}$

# Convert improper fractions to mixed numbers

## Notes and guidance

In the previous step, children converted mixed numbers to improper fractions. In this small step, they convert the other way, from improper fractions to mixed numbers.

At this stage, children explore this concept predominantly through the use of pictorial representations and concrete manipulatives, for example counters and bar models, linking back to work done on division with remainders in Spring Block 1. Children use their times-tables knowledge to find the integer part of a mixed number, with the remainder as the fractional part.

The learning from this step will be revisited and built on in Year 5.

### Things to look out for

- Fluent knowledge of times-tables will greatly support children in this step. Times-table grids could support children who are not yet fluent, allowing them to focus on the key learning of this step.
- Children may partially convert improper fractions, giving an answer as an integer with an improper fraction, for example  $\frac{11}{5} = 1 \frac{6}{5}$

## Key questions

- How do you know \_\_\_\_\_ is an improper fraction?
- How many quarters are there in  $\frac{15}{4}$ ?
- How many quarters are there in  $1\frac{1}{2}$  wholes?
- How many groups of 4 are there in 15? What is the remainder?

So how many groups of  $\frac{4}{4}$  are there in  $\frac{15}{4}$ ? What is the remainder?

How can you write that as a mixed number?

## Possible sentence stems

- There are \_\_\_\_\_ \_\_\_\_\_ in 1 whole.  
There are \_\_\_\_\_ groups of \_\_\_\_\_ and \_\_\_\_\_ remaining.  
so  $\frac{\square}{\square}$  as a mixed number is \_\_\_\_\_

## National Curriculum links

- This small step is not taken from the Year 4 National Curriculum. It is included to take into account the non-statutory DfE Ready to Progress guidance.



# Convert improper fractions to mixed numbers

## Key learning

- Eva and Jack are converting  $\frac{13}{4}$  to a mixed number.

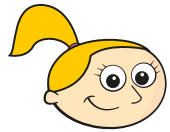
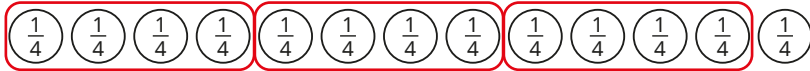

There are 3 groups of four quarters and 1 quarter remaining.

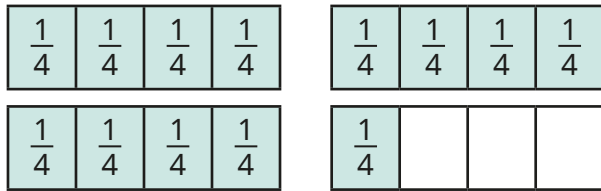

There are 3 wholes and 1 quarter.



Write  $\frac{13}{4}$  as a mixed number.

- Convert the improper fractions to mixed numbers.



- Whitney is converting  $\frac{17}{5}$  to a mixed number.

Here are her workings.



$$\begin{aligned} 15 \div 5 &= 3 \\ 17 \div 5 &= 3 \text{ r}2 \\ \frac{17}{5} &= 3\frac{2}{5} \end{aligned}$$

Use Whitney's method to convert the improper fractions to mixed numbers.

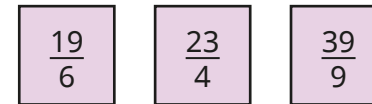

- Which of these improper fractions are equivalent to an integer?

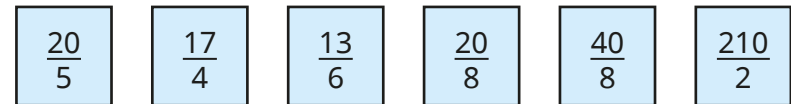

How do you know?

Convert the other improper fractions to mixed numbers.

- Convert the improper fractions to mixed numbers.



What do you notice?

# Convert improper fractions to mixed numbers

## Reasoning and problem solving

Tiny is converting  $\frac{9}{4}$  to a mixed number.



$\frac{9}{4}$  is equivalent to  $1\frac{5}{4}$

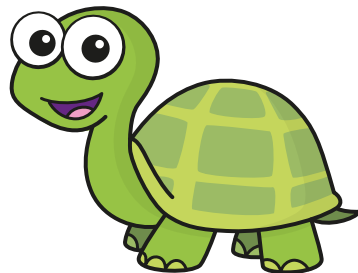

What mistake has Tiny made?  
What is the correct answer?

$2\frac{1}{4}$

$\frac{1617}{7}$  is equivalent to 231

Use this fact to convert  $231\frac{1}{7}$  to an improper fraction.

What improper fraction is equivalent to 232?

How do you know?

$$\frac{1618}{7}$$

$$\frac{1624}{7}$$

Use the digit cards to complete the statement in as many ways as possible.

You may use each digit card only once each time.

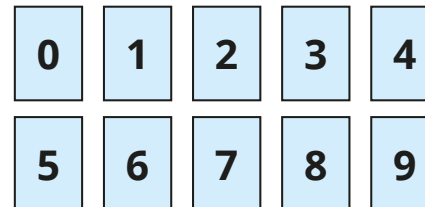

$$2 < \frac{\square\square}{5} < 4\frac{3}{5}$$

10 solutions from  $\frac{12}{5}$  to  $\frac{21}{5}$

# Equivalent fractions on a number line

## Notes and guidance

In Year 3, children used number lines to find equivalent fractions within 1 and this knowledge is now extended to numbers beyond 1

The focus of this step is on using number lines to find equivalent fractions by looking at fractions that are in line with each other (equal in value), rather than using more abstract methods of multiplicative reasoning. Drawing bars of unequal length or lining them up incorrectly are common mistakes with this method, so it is vital to highlight that integer values should always be in line with each other. Children look at multiple number lines, double number lines and splitting up existing number lines into smaller parts. They may explore equivalence of both mixed numbers and improper fractions.

### Things to look out for

- If number lines are not drawn to the same length or lined up correctly, then equivalent fractions will not be easy to see.
- Children may need support drawing and labelling number lines accurately.
- Children may use incorrect “rules” for finding equivalent fractions that can lead to incorrect equivalences such as  $2\frac{1}{3} = 4\frac{2}{6}$

## Key questions

- What are equivalent fractions?
- What unit fraction is the number line counting in?
- How do you know that \_\_\_\_\_ is equivalent to \_\_\_\_\_?
- Why do the integers have to be in line with each other?
- How do you know that  $2\frac{1}{3}$  cannot be equivalent to  $4\frac{2}{6}$ ?
- What is \_\_\_\_\_ as a mixed number/improper fraction?

## Possible sentence stems

- There are \_\_\_\_\_ equal intervals between consecutive integers, so the number line is counting in \_\_\_\_\_s.
- I know that \_\_\_\_\_ is equivalent to \_\_\_\_\_ because ...
- To split the number line into \_\_\_\_\_, I need to split each interval into \_\_\_\_\_ equal sections.

## National Curriculum links

- Recognise and show, using diagrams, families of common equivalent fractions

# Equivalent fractions on a number line

## Key learning

- The number lines show two pairs of equivalent fractions.

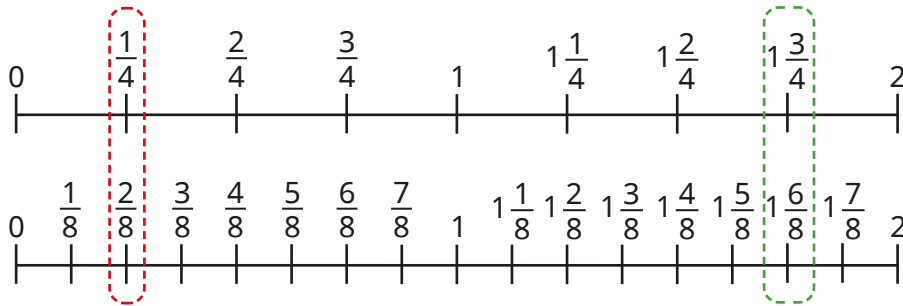

Use the number lines to find two other pairs of equivalent fractions.

- Label the number lines.

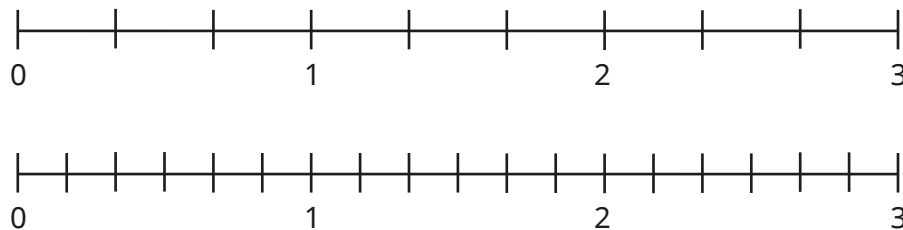

Use the number lines to complete the equivalent fractions.

$\triangleright \frac{\square}{3} = \frac{2}{6}$ 
 $\triangleright 1\frac{1}{3} = \frac{\square}{6}$ 
 $\triangleright 1\frac{4}{6} = \frac{\square}{\square}$

- Use the double number line to complete the equivalent fractions.

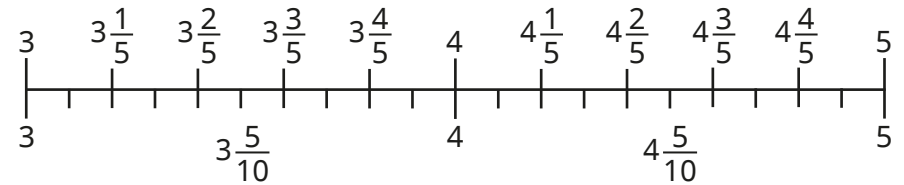

$\triangleright 3\frac{4}{5} = \frac{\quad}{\quad}$ 
 $\triangleright 4\frac{4}{10} = \frac{\quad}{\quad}$ 
 $\triangleright 5\frac{1}{5} = \frac{\quad}{\quad}$

Write the equivalent mixed numbers as improper fractions.

- Split each section of the number line into 4 equal parts.

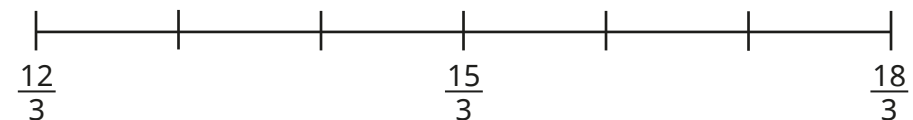

Use the number line to find two pairs of equivalent improper fractions.

Write each pair of improper fractions as mixed numbers.

# Equivalent fractions on a number line

## Reasoning and problem solving

Dora is drawing number lines to find equivalent fractions.

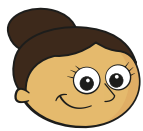
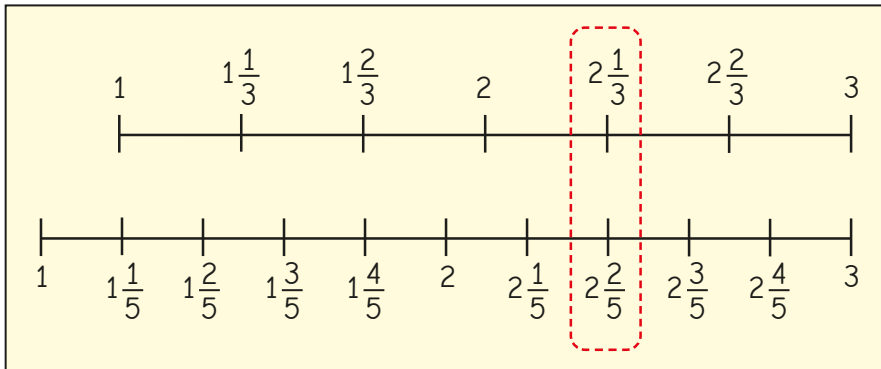

$2\frac{1}{3}$  is equivalent to  $2\frac{2}{5}$

Do you agree with Dora?  
Explain your answer.



No

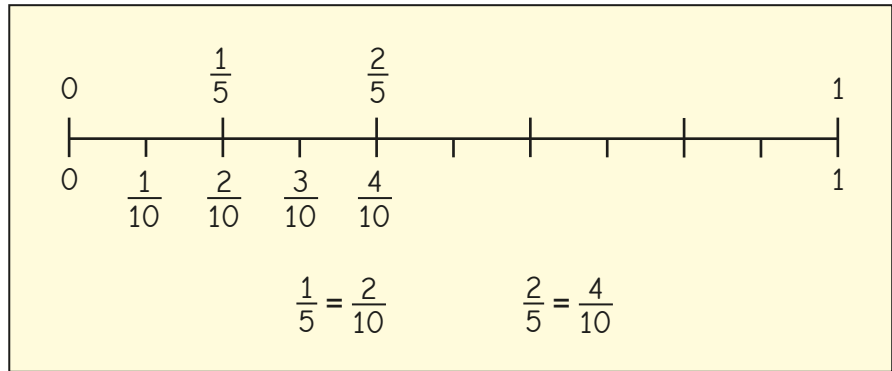

I think that  $1\frac{2}{5}$  is equivalent to  $2\frac{4}{10}$  because I can just double everything.

Do you agree with Dexter?  
Explain your answer.



No

# Equivalent fraction families

## Notes and guidance

In this small step, children develop their understanding of equivalent fractions, both within 1 and greater than 1, mainly through exploring bar models.

Building on learning from Year 3, children begin by finding equivalent fractions by splitting up models into smaller parts in a range of different ways. The key learning point is that as long as each of the existing parts are split equally into the same number of smaller parts, then the fractions will be equivalent. A common misconception is that children believe they can only split up existing parts into two equal sections, which limits the number of equivalent fractions that they will find. Children begin to use fraction walls to help create equivalent fraction families.

Although not the key focus, once children are comfortable finding equivalent fractions within 1, they may begin to find equivalent fractions greater than 1

### Things to look out for

- Children may not draw accurate diagrams, so their equivalent fractions will be incorrect.
- Children may only split existing parts into two smaller sections.

## Key questions

- How can you split each section into  $\frac{2}{3}$ / $\frac{4}{4}$  equal smaller parts? How many other ways could you split each part?
- If you split each part into \_\_\_\_\_ equal smaller parts, what fraction does each part now represent?
- Why do you need to split all of the existing parts? Why do they need to be equal in size?
- Are there any fractions on the fraction wall that do not have any equivalent fractions shown? Does this mean they do not have any equivalent fractions?

## Possible sentence stems

- If I divide each part into \_\_\_\_\_ equal parts, then they will each represent  $\frac{\square}{\square}$
- I can divide each part into \_\_\_\_\_ equal parts to show that \_\_\_\_\_ is equivalent to \_\_\_\_\_

## National Curriculum links

- Recognise and show, using diagrams, families of common equivalent fractions

# Equivalent fraction families

## Key learning

- Use the bar models to find the equivalent fractions.

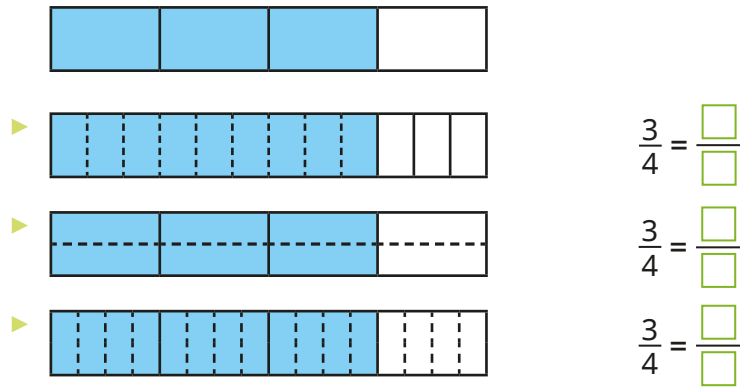

Which bar model method do you prefer for finding equivalent fractions?

Complete the fraction family.

$$\frac{3}{4} = \frac{\square}{\square} = \frac{\square}{\square} = \frac{\square}{\square}$$

- Draw bar models to help you write a fraction family for each fraction.

$\frac{4}{5}$      $\frac{2}{3}$      $\frac{1}{6}$

Compare answers with a partner.

Are your fraction families the same?

- Use the fraction wall to create equivalent fraction families.

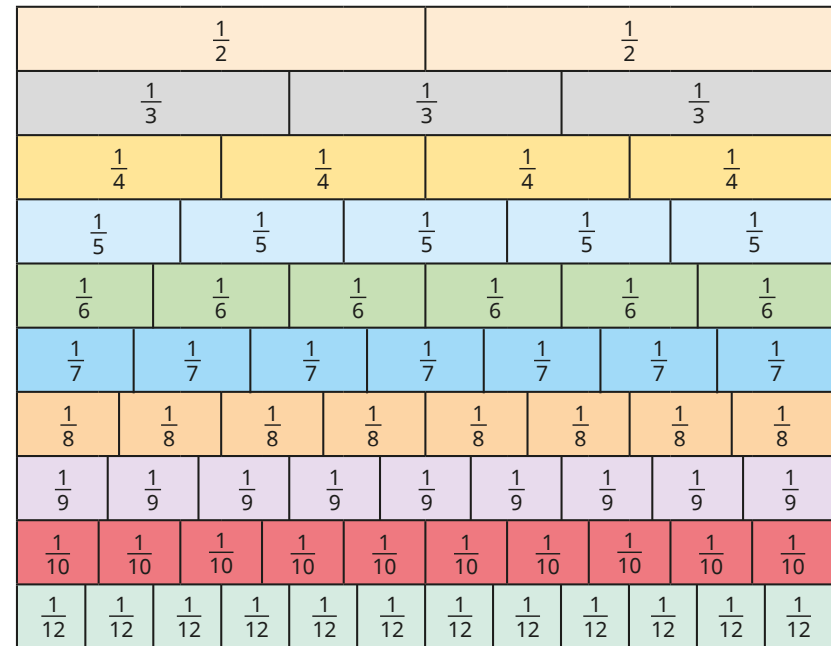

- What equivalent fractions can you see from the bar models?

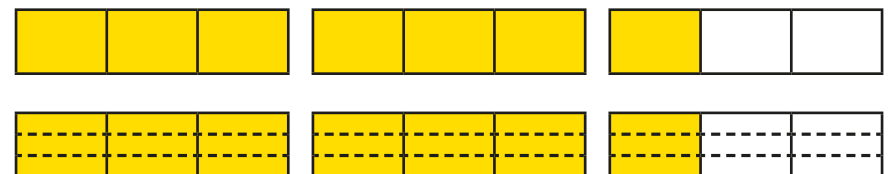

# Equivalent fraction families

## Reasoning and problem solving

Kim is finding equivalent fractions to  $\frac{2}{3}$



**A**  $\frac{2}{3} = \frac{3}{5}$

**B**  $\frac{2}{3} = \frac{6}{8}$

**C**  $\frac{2}{3} = \frac{6}{9}$

**D**  $\frac{2}{3} = \frac{6}{9}$

Which of Kim's bar models is correct?

Which of Kim's equivalent fractions are correct?

What mistakes has she made?



C

C, D

Amir is finding equivalent fractions.



If I just keep splitting each section in half, I can find all the equivalent fractions in the family.

$\frac{1}{2}$

$\frac{2}{4}$

$\frac{4}{8}$

Do you agree with Amir?

Explain your reasons.



No



# Add two or more fractions

## Notes and guidance

Building from Year 3, in this small step children add two or more fractions with the same denominator. They add proper fractions in this step and then add fractions and mixed numbers in the next step.

Children start by folding strips of paper and shading the equal parts. They transfer this knowledge to using diagrams and bar models to add two fractions, before progressing to adding more than two fractions. Children also explore adding by using a number line and counting on.

Addition with totals greater than 1 is covered in this step, but first ensure that children are secure in adding fractions within 1. Encourage children to convert improper fractions to mixed numbers, although this is not essential in this step.

### Things to look out for

- If using two bar models to add two fractions, children may think the two bar models together make 1 whole and will be unable to find the correct denominator.
- Children may add both the numerators and denominators, for example  $\frac{1}{3} + \frac{1}{3} = \frac{2}{6}$

## Key questions

- Are the denominators the same? Why is this important?
- How can you show the addition in a diagram/bar model?
- How could a number line help you?
- Is your answer greater or smaller than 1? How do you know?
- How do you convert an improper fraction to a mixed number?
- How is adding three fractions different from adding two fractions?
- How would you explain how to add fractions to someone who does not understand?

## Possible sentence stems

- When the denominators are the same, to add the fractions add the \_\_\_\_\_
- $\frac{\square}{\square}$  is the same as \_\_\_\_\_ (for example,  $\frac{5}{4}$  is the same as  $1\frac{1}{4}$ )

### National Curriculum links

- Add and subtract fractions with the same denominator

# Add two or more fractions

## Key learning

- Take two identical strips of paper.

Fold each strip in half and then in half again to make quarters.

Use the strips to work out  $\frac{1}{4} + \frac{1}{4}$

- Huan and Scott use bar models to represent  $\frac{2}{5} + \frac{2}{5} = \frac{4}{5}$

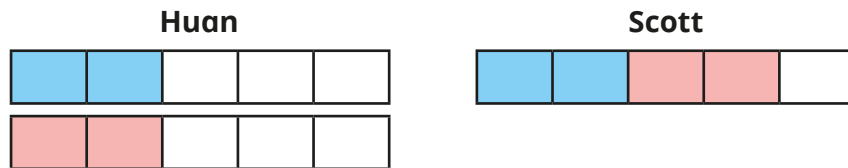

Are their methods the same or different?

Use your preferred method to work out the additions.

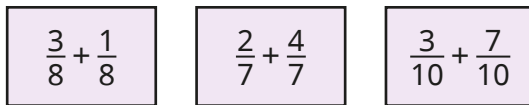

- Dani uses bar models to show that  $\frac{3}{5} + \frac{4}{5} = \frac{7}{5} = 1\frac{2}{5}$



Use Dani's method to work out the additions.



- Use the number line to add the fractions.

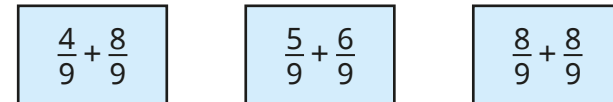
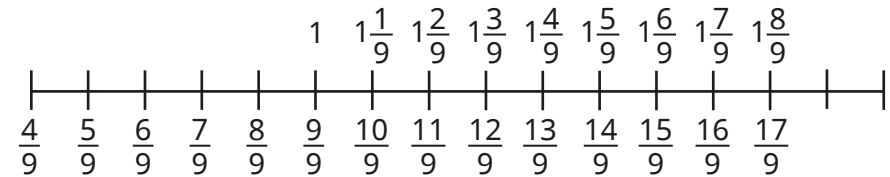

- Complete the part-whole models.

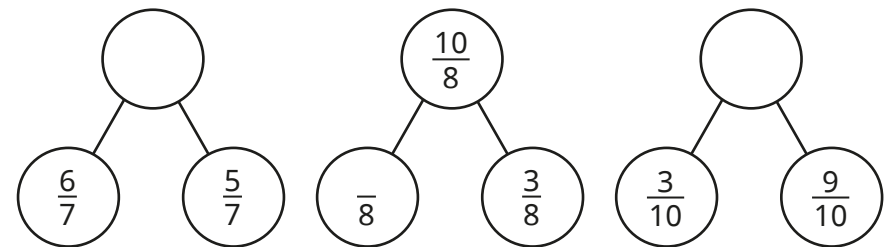

- Filip walks  $\frac{7}{10}$  km to school.  
After school, he walks  $\frac{9}{10}$  km to Aisha's house.  
How far has Filip walked in total?

# Add two or more fractions

## Reasoning and problem solving



Tiny is adding fractions.

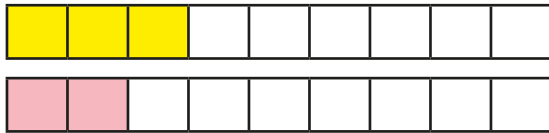

$$\frac{3}{9} + \frac{2}{9} = \frac{5}{18}$$

Is Tiny correct?

How do you know?



No

Find as many ways as possible to complete the calculation.

$$\frac{\square}{\square} + \frac{\square}{\square} = \frac{11}{9}$$



multiple possible answers, e.g.  $\frac{3}{9} + \frac{8}{9}$

Jo and Max are working out the addition.

$$\frac{6}{13} + \frac{5}{13} + \frac{7}{13}$$



Jo

The answer is 1 and  $\frac{5}{13}$

The answer is  $\frac{18}{13}$



Max

Both are correct.

Who do you agree with?

Explain your answer.



# Add fractions and mixed numbers

## Notes and guidance

In this small step, children combine knowledge of adding two or more fractions with their understanding of mixed numbers to add fractions and mixed numbers.

Children start by adding fractions to whole numbers and, when this is secure, add mixed numbers and fractions. Bar models and number lines are useful tools to illustrate this process. Number lines are especially helpful when crossing a whole. Children look at two methods: partitioning the fraction to add to the next whole number, then adding the remaining fraction to the whole number, and adding the fractions separately, then adding the total to the whole number.

### Things to look out for

- Children may add the whole number to the numerator, for example  $1\frac{3}{10} + \frac{1}{10} = \frac{4}{10} + \frac{1}{10} = \frac{5}{10}$
- Children should be encouraged to start with the mixed number, especially when using a number line.
- Children may not convert improper fractions to mixed numbers when crossing a whole, for example writing  $1\frac{6}{5}$

## Key questions

- Are the denominators the same? Why is this important?
- How is adding two fractions different from adding a fraction and a whole number? How is it different from adding a fraction and a mixed number?
- Do you prefer to use a bar model or a number line? Why?
- How could you partition the fraction to help you work out the answer?
- Do you have an improper fraction in your answer? How should you write the mixed number?

## Possible sentence stems

- If the denominators are the same, to add the fractions I need to add the \_\_\_\_\_
- I can partition \_\_\_\_\_ into \_\_\_\_\_ and \_\_\_\_\_

### National Curriculum links

- Add and subtract fractions with the same denominator

# Add fractions and mixed numbers

## Key learning

- Draw bar models to show the calculations.

$\frac{2}{5} + \frac{2}{5} = \frac{4}{5}$	$1 + \frac{2}{5} = 1\frac{2}{5}$	$\frac{2}{5} + 2 = 2\frac{2}{5}$
---	----------------------------------	----------------------------------

- Tommy uses a bar model to work out this addition.

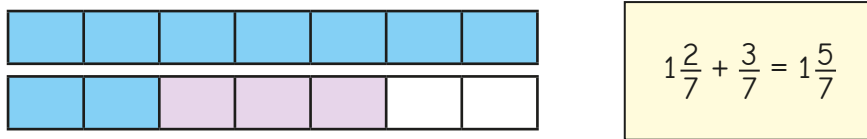

Use bar models to work out the additions.

$1\frac{3}{7} + \frac{3}{7}$	$1\frac{1}{5} + \frac{2}{5}$	$2\frac{3}{10} + \frac{6}{10}$	$\frac{7}{10} + 3\frac{1}{10}$
------------------------------	------------------------------	--------------------------------	--------------------------------

- Amir uses a number line to add fractions.

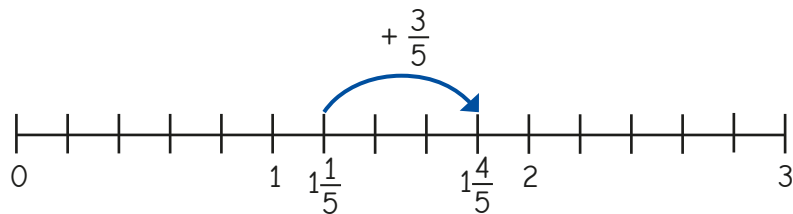

What calculation is Amir working out? What is the answer?

- Use number lines to work out the additions.

$2\frac{2}{5} + \frac{2}{5}$	$2\frac{1}{10} + \frac{6}{10}$	$1\frac{4}{5} + \frac{3}{5}$
$1\frac{1}{5} + \frac{2}{5}$	$2\frac{3}{5} + \frac{2}{5}$	$6\frac{4}{6} + \frac{5}{6}$

- Amir and Eva are working out  $1\frac{7}{9} + \frac{5}{9}$



Amir

I will add the fractions first.

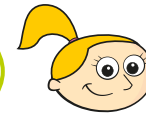

Eva

I will partition  $\frac{5}{9}$  to make it easier to add.

$$\frac{7}{9} + \frac{5}{9} = \frac{12}{9} = 1\frac{3}{9}$$

$$1\frac{3}{9} + 1 = 2\frac{3}{9}$$

$$1\frac{7}{9} + \frac{2}{9} = 1\frac{9}{9} = 2$$

$$2 + \frac{3}{9} = 2\frac{3}{9}$$

Use your preferred method to work out the additions.

$1\frac{7}{9} + \frac{8}{9}$	$\frac{3}{9} + 1\frac{8}{9}$	$2\frac{4}{5} + \frac{3}{5}$	$\frac{6}{10} + 7\frac{7}{10}$
------------------------------	------------------------------	------------------------------	--------------------------------

# Add fractions and mixed numbers

## Reasoning and problem solving

Tommy works out an addition.

$$4\frac{3}{5} + \frac{2}{5} = 4\frac{5}{5}$$

Do you agree with Tommy?

Explain your answer.



No

Whitney is working out  $1\frac{2}{5} + \frac{1}{5}$



$$1\frac{2}{5} + \frac{1}{5} = \frac{4}{5}$$

What mistake has she made?

Work out the correct answer.



$1\frac{3}{5}$

A mixed number and two different fractions have a total of  $3\frac{3}{8}$



- The mixed number is greater than 1
- All the denominators are 8
- The sum of the two fractions is  $\frac{5}{8}$

Complete the number sentence.

$$\frac{\square}{\square} + \frac{\square}{\square} + \frac{\square}{\square} = 3\frac{3}{8}$$

mixed number:  $2\frac{6}{8}$

fractions:  $\frac{3}{8} + \frac{2}{8}$   
or  $\frac{4}{8} + \frac{1}{8}$

What is the missing digit?

$$6\frac{3}{10} + \frac{\square}{10} = 7$$

What would change if the answer to the calculation was 8?



7

# Subtract two fractions

## Notes and guidance

In this small step, children subtract two fractions with the same denominator. They should link this to adding fractions with the same denominator, realising that when the denominators are the same, they need to subtract the numerators.

Children start by folding paper and then link this to diagrams and bar models. Encourage children to explore all the different structures of subtraction: taking away, partitioning and difference.

The questions in this step only explore subtracting from proper and improper fractions. Subtraction from whole numbers and mixed numbers are covered later in the block.

### Things to look out for

- Children may subtract both the numerators and the denominators, for example  $\frac{5}{8} - \frac{3}{8} = \frac{2}{0}$
- When comparing methods, children may not be aware of the different structures of subtraction.
- Children do not need to give answers as mixed numbers, but some may not recognise that an improper fraction can be converted to a mixed number.

## Key questions

- Are the denominators the same? Why is this important?
- How could you represent the subtraction in a diagram/bar model?
- How would a number line help you?
- Is your answer greater or smaller than 1? How do you know?
- What is the same when you are adding or subtracting fractions with the same denominator? What is different?
- How would you explain how to subtract fractions to someone who does not understand?

## Possible sentence stems

- If the denominators are the same, to subtract the fractions I need to subtract the \_\_\_\_\_
- \_\_\_\_\_ minus \_\_\_\_\_ is equal to \_\_\_\_\_

### National Curriculum links

- Add and subtract fractions with the same denominator

# Subtract two fractions

## Key learning

- Fold strips of paper into eighths and use them to work out the subtractions.

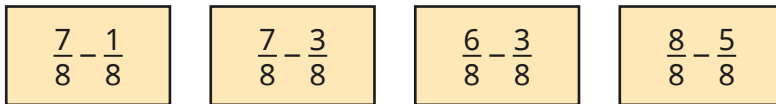

- Filip and Kim use bar models to work out  $\frac{8}{9} - \frac{3}{9} = \frac{5}{9}$

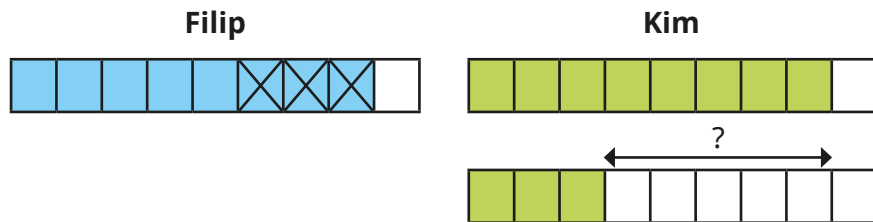

What is the same about their methods? What is different?

- Use bar models to work out the subtractions.

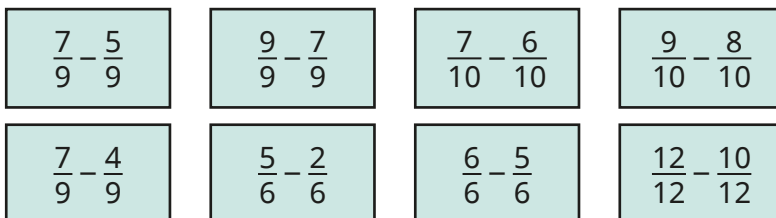

- Use the bar models to complete the calculations.

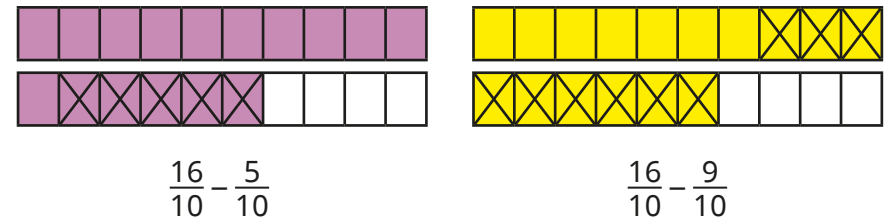

What is the same? What is different?

- Annie is using a number line to show that  $\frac{7}{6} - \frac{5}{6} = \frac{2}{6}$

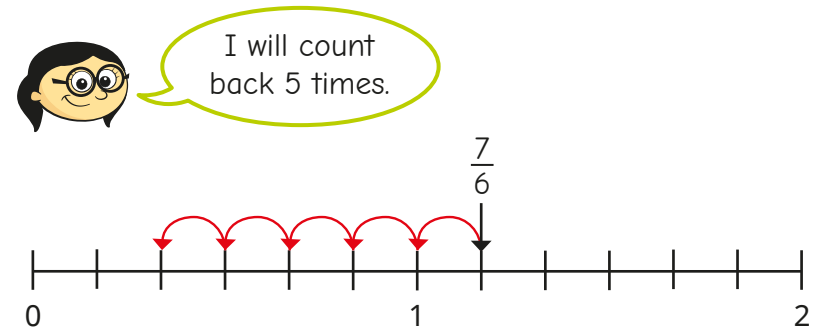

Use Annie's method to work out the subtractions.





# Subtract two fractions

## Reasoning and problem solving

Tiny is subtracting fractions.

$$\frac{7}{10} - \frac{4}{10} = 3$$

Do you agree with Tiny?

Explain your answer.



No

Complete the calculations in as many different ways as you can.



$$\frac{\square}{7} - \frac{3}{7} = \frac{\square}{7} + \frac{\square}{7}$$

$$\frac{\square}{7} - \frac{3}{7} = \frac{\square}{7} - \frac{\square}{7}$$

multiple possible answers, e.g.

$$\frac{6}{7} - \frac{3}{7} = \frac{1}{7} + \frac{2}{7}$$

$$\frac{7}{7} - \frac{3}{7} = \frac{6}{7} - \frac{2}{7}$$

Dora and Dexter are working out  $\frac{13}{3} - \frac{5}{3}$



My answer is  $\frac{8}{3}$

Dora

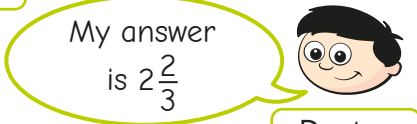

My answer is  $2\frac{2}{3}$

Dexter

Who is correct?

How do you know?



Both are correct.

A chocolate bar has been split into 10 equal parts.



Rosie eats  $\frac{3}{10}$  of the bar.

Dexter eats  $\frac{1}{10}$  of the bar more than Rosie.

What fraction of the chocolate bar is left?

$\frac{3}{10}$

# Subtract from whole amounts

## Notes and guidance

This small step links the previous step and the next step together, helping children to make links between subtracting fractions and subtracting mixed numbers and fractions.

Children need to know how many equal parts are equivalent to the whole and how this relates to whole numbers greater than 1. They use bar models and explore subtracting from the whole, initially when it is written as a fraction, for example  $\frac{9}{9}$ , rather than 1. They subtract from whole numbers greater than 1, comparing subtracting the fraction from one of the wholes with using improper fractions.

Number lines are also used in this step, and children explore the difference between taking away and finding the difference.

### Things to look out for

- Some children may not be efficient when converting whole numbers into fractions.
- Children may know that  $1 = \frac{10}{10}$  but may not be as confident that  $3 = \frac{30}{10}$
- Children may subtract the numerator from the whole, for example  $4 - \frac{1}{5} = \frac{3}{5}$

## Key questions

- How many \_\_\_\_\_ are equal to 1 whole/2 wholes/5 wholes?
- What is the connection between the numerator in the question and the numerator in the answer when you subtract a fraction from 1?
- How can you show the problem using a bar model/number line?
- How many of the wholes are affected when you subtract a fraction?
- How can you partition the whole number to help with the subtraction?

## Possible sentence stems

- $1 - \frac{\square}{\square} = \frac{\square}{\square}$ , so  $2 - \frac{\square}{\square} = 1 \frac{\square}{\square}$
- If the denominators are the same, to subtract the fractions I need to subtract the \_\_\_\_\_
- 1 whole is equal to  $\frac{\square}{\square}$ , so wholes are equal to  $\frac{\square}{\square}$

## National Curriculum links

- Add and subtract fractions with the same denominator

# Subtract from whole amounts

## Key learning

- Convert the whole numbers into fractions.

$$1 = \frac{\square}{3} \quad 1 = \frac{\square}{5} \quad 2 = \frac{\square}{5} \quad 2 = \frac{\square}{10} \quad 5 = \frac{\square}{10}$$

What do you notice?

- Use the diagrams to work out the subtractions.

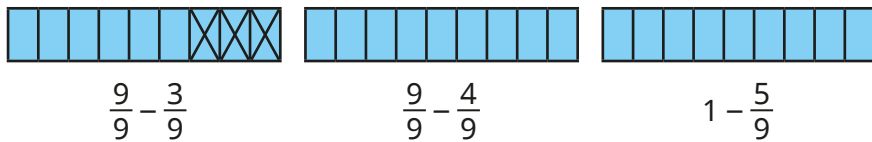

What is the same? What is different?

- Use the bar models to work out the subtractions.

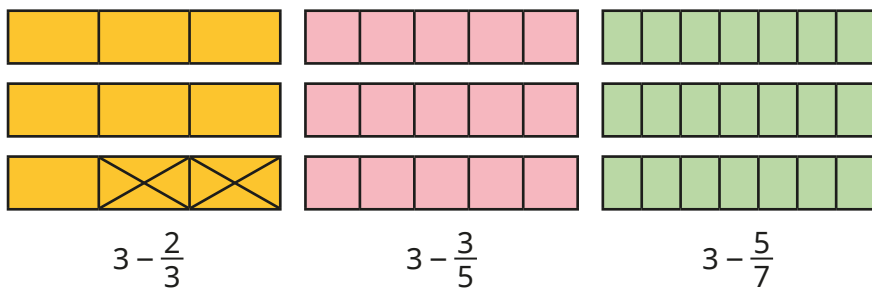

Compare answers with a partner.

- Jo uses a number line to find  $3 - \frac{4}{5} = 2\frac{1}{5}$

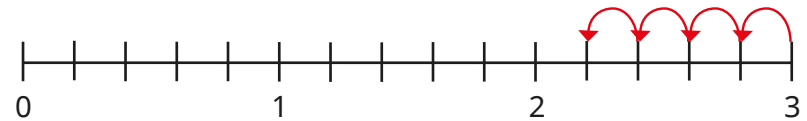

Use Jo's method to work out the subtractions.

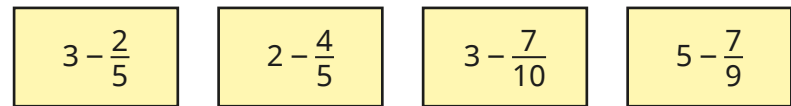

- Complete the part-whole models.

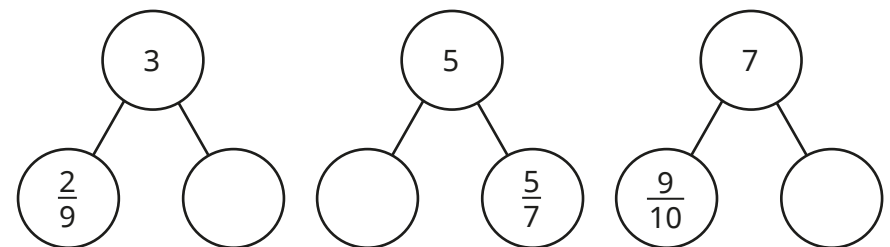

- Huan has 5 m of ribbon.  
He cuts off  $\frac{3}{5}$  m to give to Dani.  
How much ribbon is left?

# Subtract from whole amounts

## Reasoning and problem solving

Tiny is subtracting a fraction from a whole number.

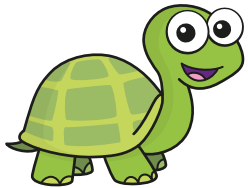

$$5 - \frac{3}{7} = \frac{2}{7}$$

$$4\frac{4}{7}$$

What mistake has Tiny made?

What is the correct answer?

Find as many ways as you can to complete the statement.

$$2 - \frac{\square}{8} = \frac{5}{8} + \frac{\square}{8}$$

multiple possible answers, e.g.

$$2 - \frac{1}{8} = \frac{5}{8} + \frac{10}{8}$$

$$2 - \frac{7}{8} = \frac{5}{8} + \frac{4}{8}$$

Complete the part-whole model.

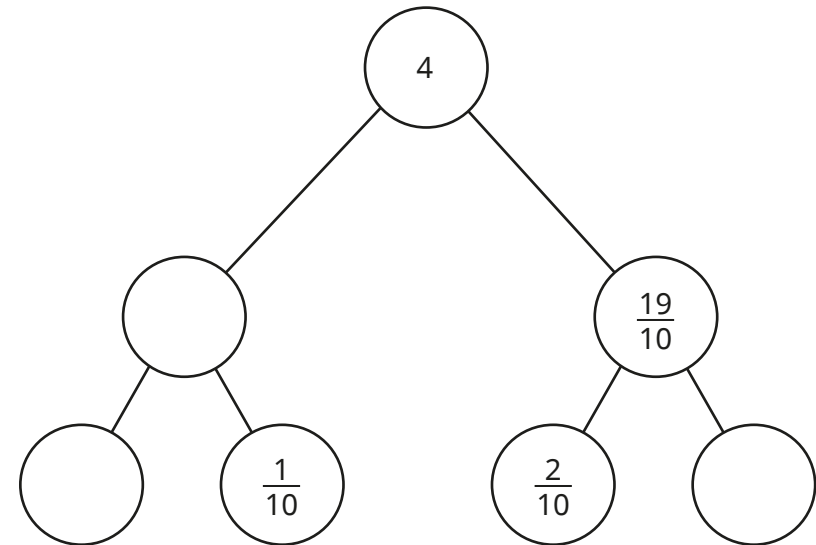

$$\frac{21}{10} \text{ or } 2\frac{1}{10}$$

$$\frac{20}{10} \text{ or } 2 \quad \frac{17}{10} \text{ or } 1\frac{7}{10}$$

# Subtract from mixed numbers

## Notes and guidance

In this small step, children subtract from mixed numbers. This step only covers subtracting a whole or a fraction from a mixed number; this will be developed in more detail and extended to subtracting mixed numbers from mixed numbers in Year 5

Children are introduced to these subtractions using bar models and number lines. Firstly, they explore what happens when they subtract a whole number from a mixed number, and then a fraction that does not cross a whole from a mixed number. Once this is secure, children complete subtractions that cross a whole number, exploring different methods.

### Things to look out for

- When subtracting a whole number from a mixed number, children may subtract a fraction instead, for example  $3\frac{4}{7} - 1 = 3\frac{3}{7}$
- Children may think they cannot complete a subtraction if the fraction they are subtracting is greater than the fractional part of the mixed number, for example  $3\frac{1}{3} - \frac{2}{3}$

## Key questions

- How is subtracting from a mixed number different from subtracting from wholes or fractions? How is it the same?
- How can you show the subtraction as a bar model? Will you subtract whole bars or parts of bars?
- How can you show the subtraction on a number line?
- How can you partition the mixed number/fraction to help you solve the calculation?
- If you subtracted back to the previous whole number, why would this help?

## Possible sentence stems

- If the denominators are the same, to subtract the fractions I need to subtract the \_\_\_\_\_
- I can partition \_\_\_\_\_ into \_\_\_\_\_ and \_\_\_\_\_
- When I subtract a whole number from a mixed number, the \_\_\_\_\_ stays the same.

### National Curriculum links

- Add and subtract fractions with the same denominator

# Subtract from mixed numbers

## Key learning

- Aisha uses a bar model to show that  $2\frac{2}{3} - 1 = 1\frac{2}{3}$

What do you notice?

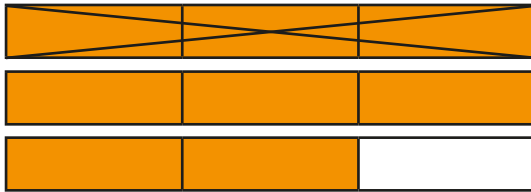

Use Aisha's method to work out the subtractions.

$3\frac{2}{3} - 2$	$2\frac{4}{5} - 1$	$5\frac{3}{10} - 3$	$4\frac{6}{7} - 4$
--------------------	--------------------	---------------------	--------------------

- Ron uses a bar model to show that  $2\frac{2}{3} - \frac{1}{3} = 2\frac{1}{3}$

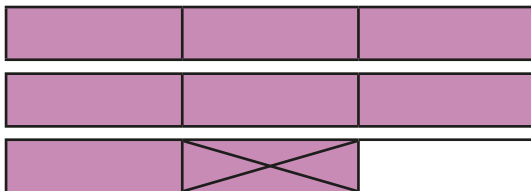

Use Ron's method to work out the subtractions.

$3\frac{4}{5} - \frac{1}{5}$	$3\frac{4}{5} - \frac{3}{5}$	$2\frac{7}{10} - \frac{3}{10}$	$3\frac{9}{10} - \frac{9}{10}$
------------------------------	------------------------------	--------------------------------	--------------------------------

- Esther and Brett are working out  $2\frac{2}{5} - \frac{4}{5} = 1\frac{3}{5}$

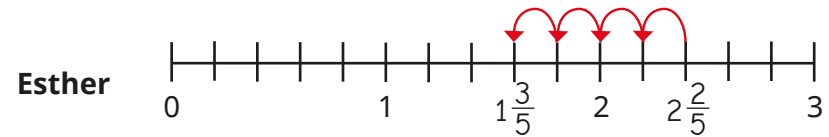

What is the same about the methods? What is different?

Use your preferred method to work out the subtractions.

$2\frac{1}{5} - \frac{4}{5}$	$3\frac{2}{5} - \frac{3}{5}$	$2\frac{1}{6} - \frac{5}{6}$	$3\frac{4}{7} - \frac{6}{7}$
------------------------------	------------------------------	------------------------------	------------------------------

- Jack has partitioned  $\frac{5}{6}$  to work out  $2\frac{4}{6} - \frac{5}{6}$

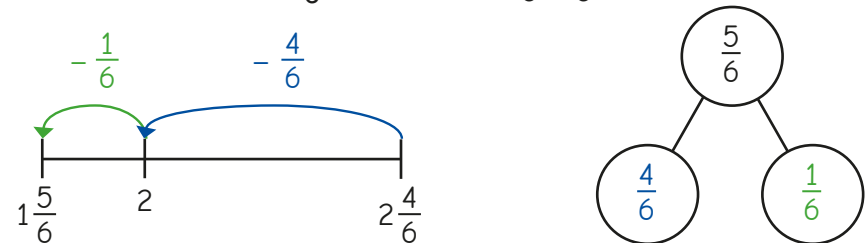

Use Jack's method to work out the subtractions.

$3\frac{2}{7} - \frac{5}{7}$	$2\frac{3}{5} - \frac{4}{5}$	$5\frac{3}{10} - \frac{7}{10}$
------------------------------	------------------------------	--------------------------------

# Subtract from mixed numbers

## Reasoning and problem solving

What subtraction does the bar model show?

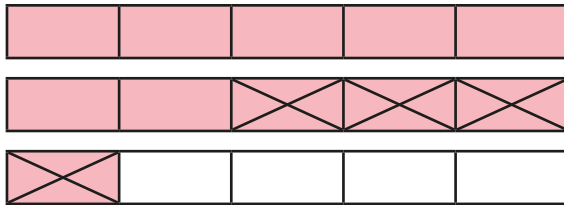

$$2\frac{1}{5} - \frac{4}{5} = 1\frac{2}{5}$$

How do you know?



A piece of ribbon is  $3\frac{1}{4}$  m long. 

Tom and Alex cut off  $\frac{3}{4}$  m of ribbon each.

Nijah needs 2 m of ribbon to complete an art project.

Is there enough ribbon left for Nijah?

Explain your answer.



No

Tiny is working out  $7\frac{1}{4} - \frac{3}{4}$



I cannot complete this because  $\frac{1}{4}$  is less than  $\frac{3}{4}$

No

Do you agree with Tiny?

Explain your answer.



Use the digit cards to complete the calculation.



$$3\frac{4}{7} - \frac{5}{7} = 2\frac{6}{7}$$

You may use each card only once.

$$\square \frac{\square}{7} - \frac{\square}{7} = 2 \frac{\square}{\square}$$

Spring Block 4

# Decimals A



## Small steps

Step 1

Tenths as fractions

Step 2

Tenths as decimals

Step 3

Tenths on a place value chart

Step 4

Tenths on a number line

Step 5

Divide a 1-digit number by 10

Step 6

Divide a 2-digit number by 10

Step 7

Hundredths as fractions

Step 8

Hundredths as decimals



## Small steps

Step 9

Hundredths on a place value chart

Step 10

Divide a 1- or 2-digit number by 100



# Tenths as fractions

## Notes and guidance

In Year 3, children were introduced to unit and non-unit fractions and learnt to compare and order these. They also explored dividing 100 into 10 equal parts on a number line, so they should already be familiar with the idea of tenths. In this small step, children explore the idea of a tenth as a fraction.

Children explore tenths through different representations of 1 whole split into ten equal parts, including place value counters, straws, counters on a ten frame and bead strings. Number lines are another useful representation of tenths as fractions, and are covered again in a later step.

At this stage, children explore tenths as fractions only – the concept of tenths as decimals is introduced later in the block.

### Things to look out for

- Children may see the pattern of  $\frac{1}{10}$ ,  $\frac{2}{10}$ ,  $\frac{3}{10}$  ... without understanding each part's worth and how it fits in with the whole.
- Seeing one-tenth in an unfamiliar place can confuse children, for example a bar split into 10 with the 9th bar shaded. Children may see this as  $\frac{9}{10}$

## Key questions

- What is a fraction?
- What is a tenth?
- If a whole is divided into 10 equal parts, what is the value of each part?
- How can you represent the fraction \_\_\_\_\_ using a model?
- When you are counting up in tenths, what comes before/after \_\_\_\_\_?
- When you are counting up in tenths, what comes after  $\frac{9}{10}$ ?
- How are tenths similar to ones?

## Possible sentence stems

- When a whole is split into \_\_\_\_\_ equal parts, one of those parts is worth \_\_\_\_\_
- When counting in tenths, the number before/after \_\_\_\_\_ is \_\_\_\_\_

### National Curriculum links

- Count up and down in tenths; recognise that tenths arise from dividing an object into 10 equal parts and in dividing 1-digit numbers or quantities by 10 (Y3)

# Tenths as fractions

## Key learning

- What fraction does each picture show?

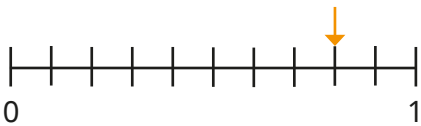
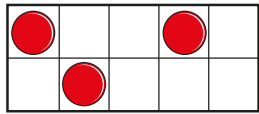
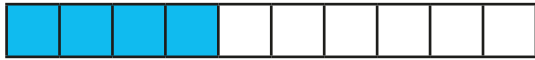

- Draw pictures to show the fractions.

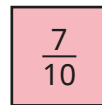
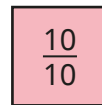
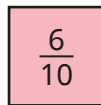
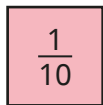

Compare drawings with a partner.

- Scott is counting up in tenths.



Continue Scott's counting until you reach 1

With a partner, count back from 1 to 0 in tenths.

- Dora has a bundle of 10 straws. She says that this bundle represents 1 whole. She gives 3 straws to Kim and 1 straw to Tommy. What fraction of the straws does Dora have left?

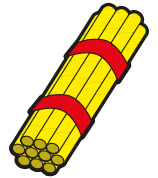

- Mo is counting up in  $\frac{2}{10}$ s.

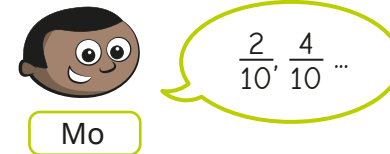

What will be the next three fractions he says?

- Annie is counting down in  $\frac{3}{10}$ s.

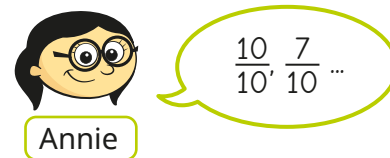

What will be the next two fractions she says?

# Tenths as fractions

## Reasoning and problem solving

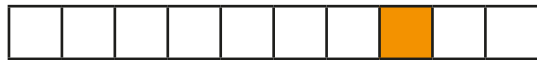

The bar model shows  $\frac{8}{10}$  because the 8th part is shaded.

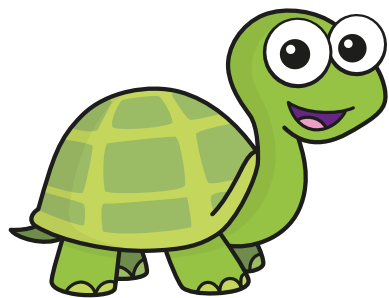

Do you agree with Tiny?  
Explain your answer.



No

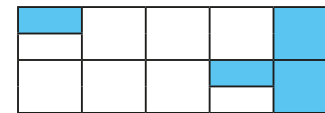

Amir

$\frac{2}{10}$  of the shape is shaded, because only 2 parts out of 10 are fully shaded.

$\frac{4}{10}$  of the shape is shaded, because 4 parts are shaded.

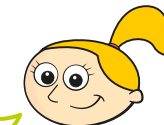

Eva

Dexter



Dexter

$\frac{3}{10}$  of the shape is shaded, because altogether 3 full parts out of 10 are shaded.

Who do you agree with?

Explain your answer.



# Tenths as decimals

## Notes and guidance

Now that children have an understanding of tenths as fractions, they move on to looking at them as decimals.

This is the first time that children have encountered decimal numbers and the decimal point. Model making, drawing and writing decimal numbers, showing that the decimal point is used to separate whole numbers from decimals.

Children look at a variety of representations of tenths as decimals, up to the value of 1 whole. This leads to adding the tenths column to a place value chart for children to see how tenths fit with the rest of the number system and to understand the need for the decimal point. This will be developed further in the next step, which explores decimal numbers beyond 1 whole.

## Things to look out for

- Children may forget to include the decimal point.
- If the number of tenths reaches 10, children may call this “zero point ten” and write 0.10 rather than exchanging for 1 one.
- Children may confuse the words “tens” and “tenths”.

## Key questions

- What is a decimal?
- What is a tenth?
- If a whole is divided into 10 equal parts, what is the value of each part?
- How can you represent the decimal \_\_\_\_\_ using a model?
- How are decimals similar to fractions?
- How can you convert between tenths as fractions and tenths as decimals?
- How is  $\frac{1}{10}$  similar to 0.1? How is it different?

## Possible sentence stems

- If a whole is split into 10 equal parts, then each part is worth \_\_\_\_\_
- Zero point \_\_\_\_\_ is equal to \_\_\_\_\_ tenths.
- \_\_\_\_\_ as a fraction/decimal is \_\_\_\_\_

## National Curriculum links

- Recognise and write decimal equivalents of any number of tenths or hundredths

# Tenths as decimals

## Key learning

- Complete the number line counting in tenths.

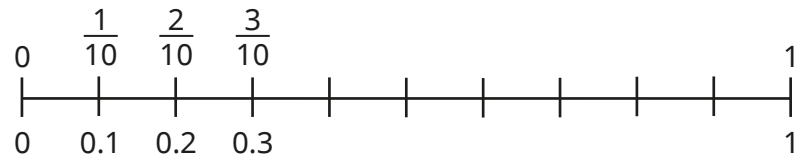

- What decimal numbers are shown by each picture?

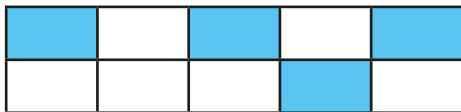
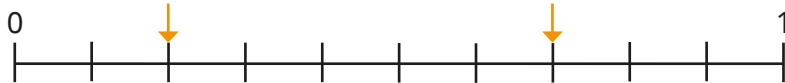

- Draw a picture to show each number.



- Complete the table.

Picture	Words	Fraction	Decimal
	one tenth	$\frac{1}{10}$	0.1
			0.9

- What number is shown on the place value chart?

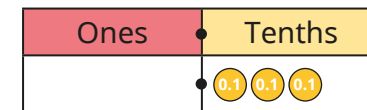

Use a place value chart to show the numbers.



- Esther puts 10 tenths into the tenths column of a place value chart. What number has she made? What does she need to do?

# Tenths as decimals

## Reasoning and problem solving

Tiny is counting up in 0.1s.

0.8, 0.9, 0.10

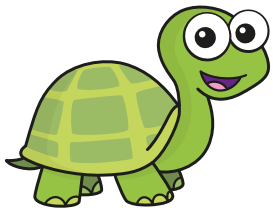

Do you agree with Tiny?  
Explain your answer.



No

Rosie thinks of a number.

$\frac{1}{10}$  more than her number is  $\frac{7}{10}$

What is Rosie's number?

Give your answer as a decimal.



0.6

Which is the odd one out?

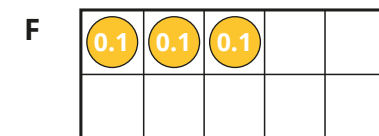
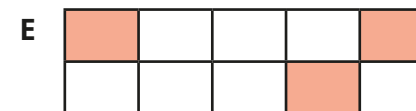
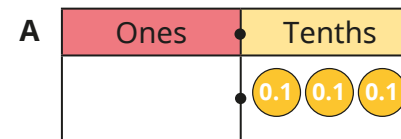

Explain your answer.



D



# Tenths on a place value chart

## Notes and guidance

In this small step, children continue to explore the tenths column in a place value chart, extending their previous learning to include numbers greater than 1

It is important that children understand that 10 tenths are equivalent to 1 whole, and therefore 1 whole is equivalent to 10 tenths. Children use this knowledge when counting both forwards and backwards in tenths. When counting forwards, children should know that 1 comes after 0.9, and when counting backwards that 0.9 comes after 1. Links can be made to the equivalence of 10 ones and 1 ten to support understanding.

### Things to look out for

- If the number of tenths reaches 10, children may call this “zero point ten” and write 0.10 rather than exchanging for 1 one.
- When counting up in tenths, children may go from 9 tenths to 0 tenths, but then forget to increase the value of the ones column, for example 1.8, 1.9, 1.0, 1.1 ...
- Similarly, when counting down in tenths, children may forget to subtract a 1 to exchange, for example 2.2, 2.1, 2.0, 2.9, 2.8 ...

## Key questions

- What is a tenth?
- What is a decimal point?
- If you have \_\_\_\_\_ in the tenths column, what number do you have?
- How many tenths make 1 whole?
- If you have 10 in the tenths column, can you make an exchange?
- How many wholes/tenths are in the number \_\_\_\_\_?

## Possible sentence stems

- There are \_\_\_\_\_ tenths in 1 whole.
- 1 whole is equivalent to \_\_\_\_\_ tenths.
- There is/are \_\_\_\_\_ whole/wholes and \_\_\_\_\_ tenths.
- The number is \_\_\_\_\_

## National Curriculum links

- Recognise and write decimal equivalents of any number of tenths or hundredths

# Tenths on a place value chart

## Key learning

- Teddy uses place value counters and a place value chart to represent the number 1.3

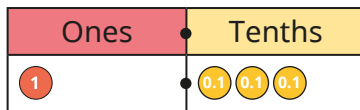

There is 1 whole and 3 tenths.  
The number is 1.3

- Use Teddy's method to represent the numbers.



- Complete the sentences for each number.

There is/are \_\_\_\_\_ whole/wholes and \_\_\_\_\_ tenths.

The number is \_\_\_\_\_

- Mo is counting up in tenths.

When he gets to 10 tenths, he exchanges them to make 1 one.

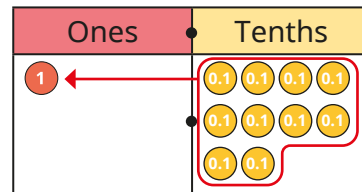

- Use place value counters to count up in 0.1s from 1 whole.

- Complete the number track.



- Complete the sentences for the number in the place value chart.

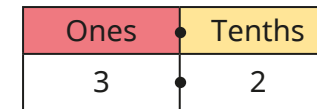

There are \_\_\_\_\_ ones and \_\_\_\_\_ tenths.

$$\begin{aligned} \text{_____ ones} + \text{_____ tenths} &= 3 + 0.2 \\ &= 3.2 \end{aligned}$$

- Use a place value chart and sentences to describe the decimals.



- Complete the number tracks.

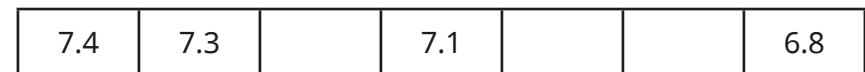
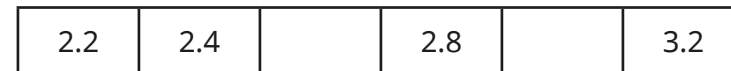
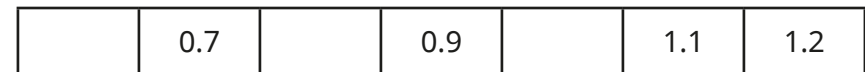

# Tenths on a place value chart

## Reasoning and problem solving

Jack uses the digit cards and the place value chart to make a number.



Ones	Tenths



My number is greater than 1 but less than 5

What number could Jack have made?  
Find as many possibilities as you can.

ten possible numbers:  
3, 3.4, 3.5, 3.6, 3.7,  
4, 4.3, 4.5, 4.6, 4.7

Rosie, Whitney and Amir are counting up in 0.1s.  
They get to this number.

Tens	Ones	Tenths
	1 1	0.1 0.1
	1 1	0.1 0.1
	1 1	0.1 0.1
	1 1	0.1 0.1
	1	0.1



The next number will be 9.10

Rosie



The next number will be 10

Amir

The next number will be 10.9



Whitney

Who do you agree with?

Explain your answer.

Amir

# Tenths on a number line

## Notes and guidance

In this small step, children extend their understanding of tenths by exploring them on a number line.

Number lines help children to see the relationship between tenths and whole numbers. They find missing decimal numbers in a sequence, deepening their understanding of the value of 1 tenth. The sequences initially go up and down in steps of 1 tenth and then in varying intervals, including crossing the whole. Seeing this modelled on a number line helps children with their understanding.

From their learning in the fractions block earlier in Year 4, children should be able to see fractions greater than 1 as mixed numbers, but for this step the numbers will be kept as decimals.

### Things to look out for

- Children may assume each interval is 0.1 without checking other numbers on the number line to see if the interval is greater than 0.1
- When counting past the whole in 0.1s, children may say "0.9, 0.10, 0.11 ..."
- When crossing the whole, children may miss out the whole number, for example 0.8, 0.9, 1.1, 1.2 ...

## Key questions

- How can you show these numbers on a number line?
- If there are 10 intervals between two whole numbers, what is each interval worth?
- How can you work out the missing number in the sequence?
- What intervals does the number line go up in?
- How do you count in 0.1s past a whole number?

## Possible sentence stems

- The start point is \_\_\_\_\_  
The end point is \_\_\_\_\_  
The number line is counting up in \_\_\_\_\_
- The missing number is \_\_\_\_\_ because ...

## National Curriculum links

- Recognise and write decimal equivalents of any number of tenths or hundredths
- Compare numbers with the same number of decimal places up to 2 decimal places

# Tenths on a number line

## Key learning

- Dani is counting in tenths on a number line.

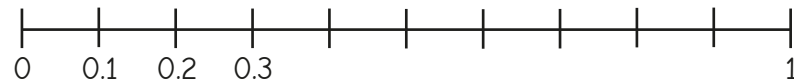

Finish labelling Dani's number line.

- Label the numbers on the number line.

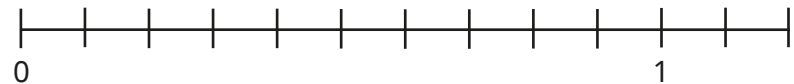
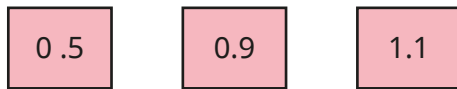

- Complete the number line.

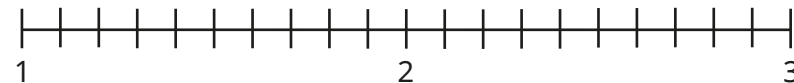

- What number is the arrow pointing to?

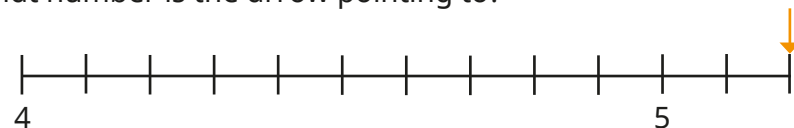

- How long is the ribbon?



- Brett has drawn this number line.

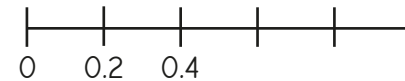

- Complete the sentences to describe Brett's number line.

The start point is \_\_\_\_\_

The end point is \_\_\_\_\_

The number line is counting up in \_\_\_\_\_

- Label the missing numbers on the number line.

- How much longer is the blue ribbon than the red ribbon?

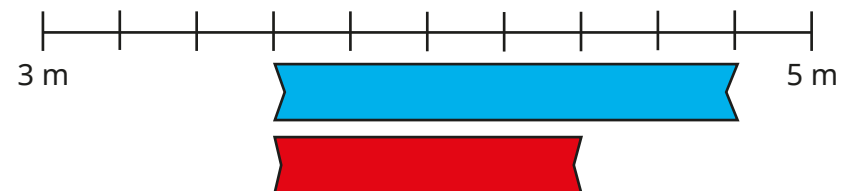

# Tenths on a number line

## Reasoning and problem solving

Tiny has drawn arrows to two numbers, A and B, on two number lines.

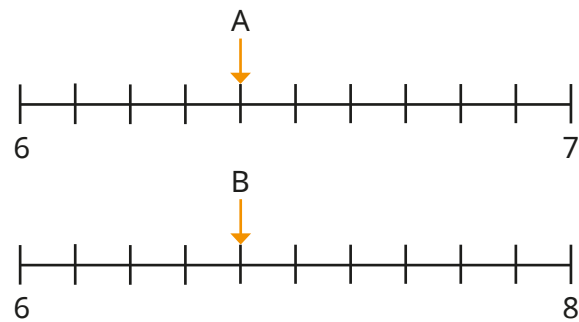

A and B are equal, because the arrows are pointing to the same place.

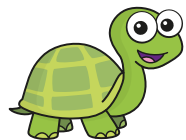

Do you agree with Tiny?  
Explain your answer.

No

Estimate the positions of the numbers on the number line.

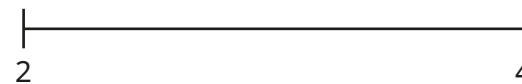

Talk about your method with a partner.

In which order did you place your numbers on the number line?

arrows pointing approximately to the correct positions

# Divide a 1-digit number by 10

## Notes and guidance

In this small step, children divide a 1-digit number by 10, resulting in a decimal number with 1 decimal place.

To begin with, they see that the number is shared into 10 equal parts. This can be shown by exchanging each place value counter worth 1 for ten 0.1 counters.

They recognise that when using a place value chart, they move all of the digits one place to the right when dividing by 10. Any misconceptions around “tricks” that work for this step, such as moving the decimal point to the beginning of the number or adding “zero point” in front of the word should be addressed at this stage. This will help to prevent errors later on, when children progress to dividing 2-digit numbers by 10 and then move on to dividing by 100 and dividing by decimals.

## Things to look out for

- Children may overgeneralise and see dividing by 10 as putting the decimal point in front of the number.
- Children may move the digits in the wrong direction.

## Key questions

- What number is represented on the place value chart?
- When dividing a number by 10, how many equal parts is the number split into?
- How many tenths are there in 1 whole/2 wholes/3 wholes?
- How can you use counters and a place value chart to show dividing a number by 10?
- What is the same and what is different before and after a 1-digit number is divided by 10?

## Possible sentence stems

- \_\_\_\_\_ is 10 times the size of \_\_\_\_\_
- \_\_\_\_\_ is one-tenth the size of \_\_\_\_\_

## National Curriculum links

- Find the effect of dividing a 1- or 2-digit number by 10 and 100, identifying the value of the digits in the answer as ones, tenths and hundredths

# Divide a 1-digit number by 10

## Key learning

- Huan is dividing 1 by 10

He exchanges 1 whole for 10 tenths and uses a ten frame to share the counters.

He knows that one of these counters is the answer to  $1 \div 10$

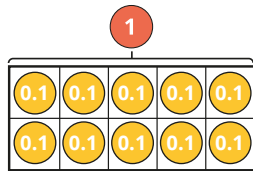

- Use Huan's model to work out the answer to  $1 \div 10$

- Use Huan's method to work out  $2 \div 10$

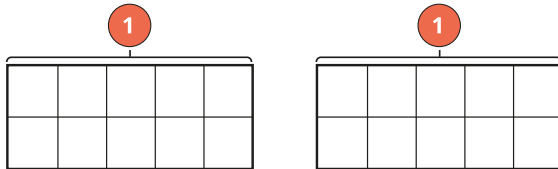

- Use counters to help you work out the divisions.



What do you notice about your answers?

- Dora uses a place value chart to work out that  $2 \div 10 = 0.2$

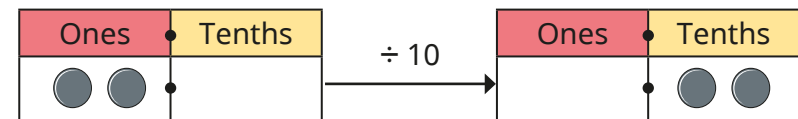

- What is the value of the 2 in the question?
- What is the value of the 2 in the answer?

- Use a place value chart to find the missing numbers.

$8 \div 10 = \underline{\quad}$      $\underline{\quad} = 9 \div 10$      $0.4 = \underline{\quad} \div 10$

- Write  $<$ ,  $>$  or  $=$  to make the statements correct.

$5 \div 10$    $10 \div 5$

3 tens   $3 \div 10$

7 tenths   $7 \div 10$

$3 \div 10$    $4 \div 10$



# Divide a 1-digit number by 10

## Reasoning and problem solving

Choose a digit card from 1 to 9 and place a counter over the top of that number on the Gattegno chart.



10	20	30	40	50	60	70	80	90
1	2	3	4	5	6	7	8	9
0.1	0.2	0.3	0.4	0.5	0.6	0.7	0.8	0.9



To divide by 10,  
I need to move the  
counter to the right.

Do you agree with Tommy?

Use the Gattegno chart to explain your answer.



No

Complete the number sentences.



$$4 \div 10 = 8 \div \underline{\quad} \div 10$$

$$15 \div 3 \div 10 = \underline{\quad} \div 10$$

$$64 \div \underline{\quad} \div 10 = 32 \div 4 \div 10$$

$$\underline{\quad} \times 10 = 6$$

2  
5  
8  
0.6

Max thinks of a number and  
divides it by 10



The answer is  
equal to 4 wholes  
and 7 tenths.

What number was Max thinking of?

47

# Divide a 2-digit number by 10

## Notes and guidance

In this small step, children divide 2-digit numbers by 10, building on their learning from the previous step.

Counters on a place value chart are a good resource for this concept. Children make the number using counters, then move all the counters one place to the right. The key learning is that both digits of the number move in the same direction by the same number of places. The digits are together before dividing and are still together after dividing.

Children may think that certain “tricks” always work, such as placing a decimal point between the digits. Reinforce with children that this does not always work and so is not a method they should rely on. Also discuss that if a multiple of 10 is divided by 10, then nothing is needed in the tenths column, for example  $50 \div 10 = 5$ , not 5.0

## Things to look out for

- If children are not using a place value chart, they may move the digits an incorrect number of places.
- Children may move only one of the digits one place to the right.
- Children may forget to add the decimal point to their answer, in effect leaving the original number unchanged.

## Key questions

- How can you show this 2-digit number on a place value chart?
- How can you show this 2-digit number in a part-whole model?
- When dividing a number by 10, how many equal parts are you splitting it into?
- How can you use a part-whole model to help you divide a 2-digit number by 10?
- What could a 2-digit number look like once it has been divided by 10?
- What happens to a number when you divide it by 10?

## Possible sentence stems

- \_\_\_\_\_ divided by 10 is equal to \_\_\_\_\_

## National Curriculum links

- Recognise and write decimal equivalents of any number of tenths or hundredths
- Find the effect of dividing a 1- or 2-digit number by 10 and 100, identifying the value of the digits in the answer as ones, tenths and hundredths

# Divide a 2-digit number by 10

## Key learning

- Kim knows that to divide a number by 10, she must split it into 10 equal groups.

She uses partitioning to divide 21 by 10

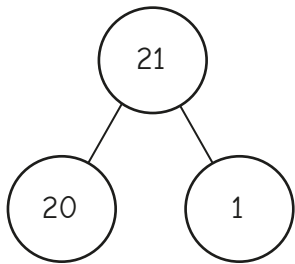

$$20 \div 10 = 2$$

$$1 \div 10 = 0.1$$

$$\text{So } 21 \div 10 = 2 + 0.1 = 2.1$$

Use Kim's method to work out the divisions.

52 ÷ 10

27 ÷ 10

19 ÷ 10

37 ÷ 10

- Filip uses a place value chart to find that  $34 \div 10 = 3.4$

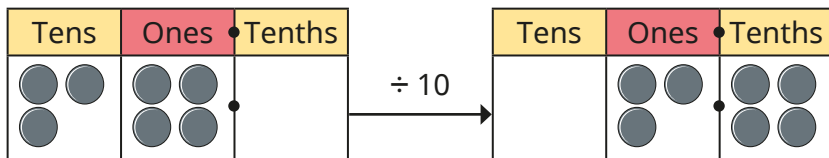

Use Filip's method to work out the divisions.

12 ÷ 10

45 ÷ 10

90 ÷ 10

80 ÷ 10

78 ÷ 10

- Jack uses a Gattegno chart to work out that  $23 \div 10 = 2.3$

10	20	30	40	50	60	70	80	90
1	2	3	4	5	6	7	8	9
0.1	0.2	0.3	0.4	0.5	0.6	0.7	0.8	0.9

Use Jack's method to work out the divisions.

27 ÷ 10

65 ÷ 10

91 ÷ 10

30 ÷ 10

- Write <, > or = to make the statements correct.

$50 \div 10$  ○  $45 \div 10$

$85 \div 10$  ○  $90 \div 10$

double 0.2 ○  $22 \div 10$

halfway between 4 and 5 ○  $46 \div 10$

- Eva has 34 cm of ribbon.

She cuts it up to share equally between her 10 friends.

What length of ribbon do they each get?

# Divide a 2-digit number by 10

## Reasoning and problem solving

Max is thinking of a 2-digit number.



I am going to divide my number by 10

I know that Max's answer must have some ones and some tenths.

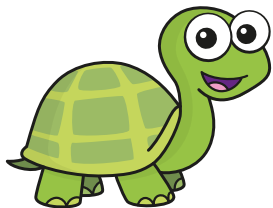

Do you agree with Tiny?  
Explain your answer.

No

Max might be thinking of a multiple of 10, e.g. 50

$50 \div 10 = 5$  and 5 does not have a digit in the tenths column.

Jo has used a Gattegno chart to divide a 2-digit number by 10



Here is her answer.

10	20	30	40	50	60	70	80	90
1	2	3	4	5	6	7	8	9
0.1	0.2	0.3	0.4	0.5	0.6	0.7	0.8	0.9

What was Jo's original number?

How does the Gattegno chart help?



26

Sam thinks of a 2-digit number.

When she divides it by 10, the answer has 4 tenths.

Is Sam's number even or odd?

How do you know?



even

# Hundredths as fractions

## Notes and guidance

In this small step, children build on their previous learning of tenths as they begin to explore hundredths. They learn that a hundredth is 1 whole split into 100 equal parts. This idea can be explored using a variety of representations, including hundred squares, bead strings, Rekenreks and number lines. Place value charts representing hundredths are introduced in a later step.

Children relate this learning to the previous steps by understanding that 1 tenth is equivalent to  $\frac{10}{100}$ . They partition hundredths into tenths and hundredths, for example  $\frac{21}{100}$  is made up of  $\frac{2}{10}$  and  $\frac{1}{100}$ , or  $\frac{1}{10}$  and  $\frac{11}{100}$

### Things to look out for

- Children may incorrectly partition a fraction and think that, for example,  $\frac{12}{100}$  is made up of  $\frac{1}{100}$  and  $\frac{2}{100}$
- Children may confuse the words “hundred” and “hundredth”.
- Children may think that hundredths are greater than tenths because 1 hundred is greater than 1 ten.

## Key questions

- How many hundredths are there in 1 whole?
- How is a hundredth similar to/different from a tenth?
- How can you represent hundredths in a hundred square?
- How many hundredths are equivalent to 1 tenth?
- How can you use base 10 to represent both tenths and hundredths?
- How can you partition \_\_\_\_\_ into tenths and hundredths?

## Possible sentence stems

- There are \_\_\_\_\_ hundredths in \_\_\_\_\_ tenths.
- \_\_\_\_\_ hundredths is equivalent to \_\_\_\_\_ tenths and \_\_\_\_\_ hundredths.

## National Curriculum links

- Count up and down in hundredths; recognise that hundredths arise when dividing an object by 100 and dividing tenths by 10
- Recognise and show, using diagrams, families of common equivalent fractions

# Hundredths as fractions

## Key learning

- Each part of a hundred square is worth  $\frac{1}{100}$   
What fraction of each hundred square is shaded?

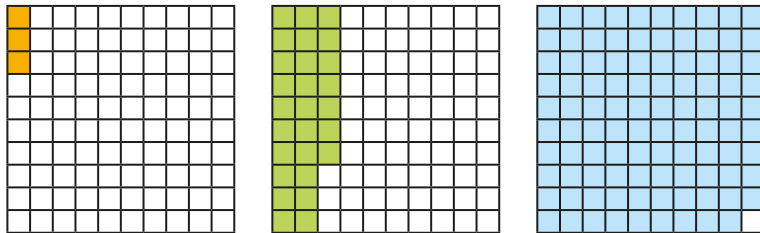

- This Rekenrek is made up of 100 beads.

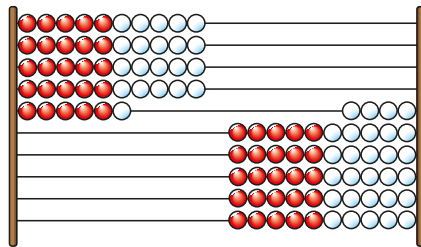

If the Rekenrek represents 1 whole, what fraction is shown on the left?

What fraction is shown on the right?

- Use a hundred square to help fill in the missing numbers.

$\frac{3}{10} = \frac{\square}{100}$      
  $\frac{70}{100} = \frac{\square}{10}$      
  $\frac{90}{100} = \frac{\square}{10}$

- Eva uses a hundred square to see that  $\frac{23}{100}$  is equivalent to  $\frac{2}{10} + \frac{3}{100}$

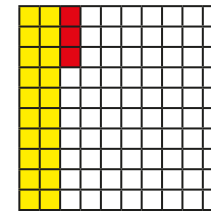

Use Eva's method to help fill in the missing numbers.

$\frac{45}{100} = \frac{\square}{10} + \frac{\square}{100}$      
  $\frac{59}{100} = \frac{\square}{10} + \frac{\square}{100}$      
  $\frac{\square}{100} = \frac{7}{10} + \frac{73}{100}$

- Dexter has partitioned  $\frac{34}{100}$  into  $\frac{2}{10}$  and  $\frac{14}{100}$

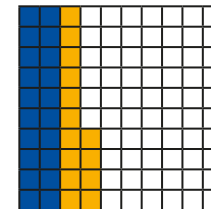

Use Dexter's method to partition the numbers in two different ways.

$$\frac{52}{100}$$

$$\frac{81}{100}$$

$$\frac{39}{100}$$

# Hundredths as fractions

## Reasoning and problem solving

45 hundredths is greater than 5 tenths, because 45 is greater than 5

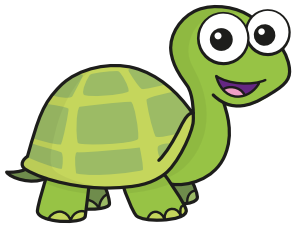

No

Do you agree with Tiny?  
Explain your answer.



Work out the missing number.

$$\frac{3}{10} + \frac{12}{100} = \frac{\square}{100}$$

How did you work it out?



42

Fill in the missing numbers.



$$\frac{3}{10} + \frac{2}{100} = \frac{2}{10} + \frac{\square}{100}$$

$$\frac{14}{100} + \frac{3}{10} = \frac{4}{10} + \frac{\square}{100}$$

$$\frac{5}{10} + \frac{1}{100} < \frac{5}{10} + \frac{\square}{100}$$

$$\frac{5}{10} + \frac{1}{100} > \frac{\square}{10} + \frac{5}{100}$$

$$\frac{37}{100} + \frac{\square}{100} = \frac{100}{100}$$

$$\frac{2}{10} + \frac{\square}{100} = 1$$

12

4

any number greater than 1

0, 1, 2, 3 or 4

63

80

Is there more than one answer for each number sentence?



# Hundredths as decimals

## Notes and guidance

Now that children have an understanding of hundredths as fractions, in this small step they explore hundredths as decimals.

Representations such as hundred squares, Rekenreks and bead strings continue to be used to help understanding, and in this step 0.01 decimal place value counters are also introduced. Children explore the idea that ten 0.01s are equivalent to 0.1, meaning that decimal numbers can be partitioned into tenths and hundredths, for example  $0.12 = 0.1 + 0.02$ . When confident with this, they also explore flexible partitioning of numbers, for example  $0.23 = 0.2 + 0.03$  or  $0.1 + 0.13$ . Encourage children to think back to the learning from the previous step and to make links between hundredths as fractions and hundredths as decimals.

## Things to look out for

- Children may confuse tenths and hundredths by missing out a zero from their decimal number, e.g.  $\frac{3}{100} = 0.3$
- Children may think that a larger number of hundredths is greater than a smaller number of tenths, e.g.  $0.06 > 0.1$
- Children may confuse the words “hundred” and “hundredth”.

## Key questions

- How is a decimal similar to/different from a fraction?
- How many hundredths are there in 1 whole?
- How can you write 1 hundredth as a decimal number?
- Are  $\frac{1}{100}$  and 0.01 the same or different?
- Is \_\_\_\_\_ greater or smaller than \_\_\_\_\_?
- How many hundredths are equivalent to 1 tenth?

## Possible sentence stems

- \_\_\_\_\_ hundredths as a decimal is \_\_\_\_\_
- There are \_\_\_\_\_ hundredths in 1 tenth.
- \_\_\_\_\_ hundredths can be partitioned into \_\_\_\_\_ tenths and \_\_\_\_\_ hundredths.

## National Curriculum links

- Recognise and write decimal equivalents of any number of tenths or hundredths
- Compare numbers with the same number of decimal places up to 2 decimal places



# Hundredths as decimals

## Key learning

- Dexter makes a number using place value counters.

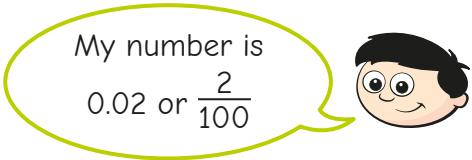

- ▶ What do these place value counters represent?



Give your answer as a fraction and as a decimal.

- ▶ Make a number using hundredth place value counters for a partner to write as a decimal and as a fraction.

- Annie makes 0.23 using place value counters.



What numbers do these counters represent?



Give your answers as decimals.

- Complete the table.

Picture	Words	Fraction	Decimal
	fifty-six hundredths		
		$\frac{17}{100}$	

- Dani uses a bead string to partition 0.34 into 0.3 and 0.04



She can also partition 0.34 into 0.2 and 0.14



Find different ways to partition the numbers.

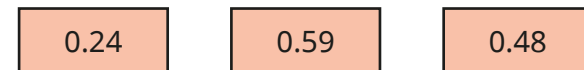

Compare answers with a partner.

# Hundredths as decimals

## Reasoning and problem solving

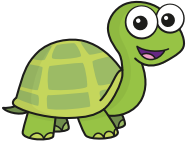

8 hundredths is the same as 800

No

Do you agree with Tiny?  
Explain your answer.



0	1	2	3	4
5	6	7	8	9



multiple possible answers, e.g.  
7 and 9  
3 and 8

0.8  < 0.  5

Which of the digit cards can be used to make this statement correct?

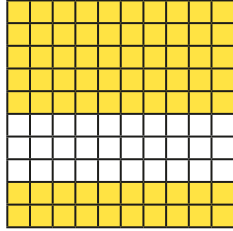

Alex and Amir have been asked what decimal is shown on the hundred square.

The square shows 0.70

Alex



The square shows 0.7

Amir

They are both correct, but the zero is not needed as a placeholder in the hundredths column.

Who do you agree with?  
Explain your answer.



# Hundredths on a place value chart

## Notes and guidance

In this small step, children continue to explore hundredths as decimals by looking at the hundredths column in a place value chart.

Children should be confident with the understanding that 10 hundredths make up 1 tenth. Exchanging ten 0.01 counters for one 0.1 counter in a place value chart will help to reinforce this understanding. It is important that children understand that 0.1 is greater than 0.09 even though 1 is less than 9. This can be seen when putting both numbers in a place value chart and considering the value of each column.

Children use place value counters to flexibly partition decimal numbers involving tenths and hundredths.

Discuss with children why no zero placeholder is needed in the hundredths column if there are no digits after the tenths, for example 1.5, not 1.50

## Things to look out for

- Children may not realise that, for example,  $0.3 = 0.30$
- Children may see numbers such as 0.45 as greater than 0.5 because 45 is greater than 5
- Children may confuse the words “hundred” and “hundredth”.

## Key questions

- What is a hundredth?
- How many hundredths are equivalent to 1 tenth?
- How many hundredths are equivalent to 1 whole?
- Is \_\_\_\_\_ greater/smaller than \_\_\_\_\_?
- How can you represent this decimal number on a place value chart?
- How is the hundredths column on a place value chart similar to/different from the \_\_\_\_\_ column?

## Possible sentence stems

- \_\_\_\_\_ is equal to \_\_\_\_\_ ones, \_\_\_\_\_ tenths and \_\_\_\_\_ hundredths.

## National Curriculum links

- Recognise and write decimal equivalents of any number of tenths or hundredths
- Compare numbers with the same number of decimal places up to 2 decimal places

# Hundredths on a place value chart

## Key learning

- Write the decimal numbers shown in the place value charts.

How many ones, tenths and hundredths are there in each number?

Ones	Tenths	Hundredths
1	0.1 0.1	0.01 0.01 0.01

Ones	Tenths	Hundredths
1 1		0.01 0.01 0.01

Ones	Tenths	Hundredths
1 1 1		0.01 0.01 0.01 0.01

- Use a place value chart and counters to make the numbers.

0.34	2.15	0.03	1.01
------	------	------	------

Complete the sentences to describe each number.

There are \_\_\_\_\_ ones.

There are \_\_\_\_\_ tenths.

There are \_\_\_\_\_ hundredths.

The number represented is \_\_\_\_\_

- Brett uses place value counters to partition 0.23



$$0.23 = 0.2 + 0.03$$



$$0.23 = 0.1 + 0.13$$

Use Brett's method to help you partition the numbers in three different ways.

0.34

0.68

0.92

0.51

- Write  $<$ ,  $>$  or  $=$  to complete the statements.

$$0.01 \bigcirc \frac{1}{100}$$

$$0.4 \bigcirc 0.05$$

$$\frac{3}{10} \bigcirc 0.31$$

$$\text{eleven hundredths} \bigcirc 0.11$$

# Hundredths on a place value chart

## Reasoning and problem solving

 0.09 is greater than 0.1 because 9 is greater than 1

Do you agree with Dora?  
Use a place value chart to help you explain your answer.





No

Is the statement always true, sometimes true or never true?

A number with 5 in the hundredths column is smaller than a number with 6 in the tenths column.

Explain your answer.





sometimes true

Eva and Max are each thinking of a number.

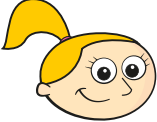
 My number can be partitioned into 3 tenths and 24 hundredths.

Eva

 My number has 5 tenths, so my number must be greater than Eva's.

Max

Do you agree with Max?  
Explain your answer.





No

# Divide a 1- or 2-digit number by 100

## Notes and guidance

Building on their learning from the multiplication and division block and the earlier steps in this block, in this small step children divide 1- and 2-digit numbers by 100

Children should build numbers using place value counters and use exchanges to support their understanding. Once confident working with place value counters, they could move to using place value charts and recognise that dividing a number by 100 moves all the counters two places to the right. Exploring the difference between moving two places for 100 and one place for 10 is important at this stage.

### Things to look out for

- Children may move just one of the digits rather than all of them.
- Children may move the digits one place instead of two places.
- Children may move the decimal point two places as well as the digits and so keep the original number.
- Children may spot “tricks” that work for some questions and they should be reminded that these do not work in all cases, so are not a reliable method.

## Key questions

- What exchanges can you make?
- How can you use a place value chart to show dividing a number by 100?
- How is dividing by 100 similar to/different from dividing by 10?
- What happens to a number when you divide it by 100?
- Does the decimal point ever move?
- If you divide by 10 twice, what do you notice?

## Possible sentence stems

- To divide something by \_\_\_\_\_, split it into \_\_\_\_\_ equal parts.
- When dividing a number by 100, move all the digits \_\_\_\_\_ places to the \_\_\_\_\_

## National Curriculum links

- Recognise and write decimal equivalents of any number of tenths or hundredths
- Find the effect of dividing a 1- or 2-digit number by 10 and 100, identifying the value of the digits in the answer as ones, tenths and hundredths

# Divide a 1- or 2-digit number by 100

## Key learning

- Rosie uses a place value chart to divide 21 by 100. She divides it first by 10, and then by 10 again.

T	O	Tths	Hths
●●	●		

÷ 10

T	O	Tths	Hths
	●●	●	

÷ 10

T	O	Tths	Hths
		●●	●

$21 \div 10 = 2.1$   
 $2.1 \div 10 = 0.21$   
 So  $21 \div 100 = 0.21$

Use Rosie's method to work out the divisions.

$26 \div 100$	$52 \div 100$	$4 \div 100$
---------------	---------------	--------------

$35 \div 100$	$78 \div 100$	$9 \div 100$
---------------	---------------	--------------

What do you notice about the divisions and the answers?

- Here is a 2-digit number on a place value chart.

T	O	Tths	Hths
7	2		

- Complete the sentences.

When dividing by 100, move the digits two places to the \_\_\_\_\_

$72 \div 100 = \underline{\quad}$

- Use this method to fill in the missing numbers.

$82 \div 100 = \underline{\quad}$

$\underline{\quad} = 93 \div 100$

$0.23 = \underline{\quad} \div 100$

- Write  $<$ ,  $>$  or  $=$  to complete the statements.

$99 \div 100$  ○  $100 \div 100$

$86 \div 100$  ○  $26 \div 10$

$4 \div 10$  ○  $50 \div 100$

$24 \div 6$  ○  $40 \div 100$

# Divide a 1- or 2-digit number by 100

## Reasoning and problem solving

Is the statement true or false?

When you divide any whole 2-digit number by 100, there will be a zero in the ones column.

True

Explain your answer.



Tiny is working out  $45 \div 100$

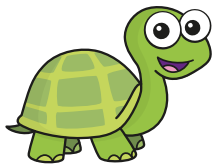

The answer is 40.05 because the 5 moves two places to the right.

No

Do you agree with Tiny?

Explain your answer.



Fill in the missing numbers.

$$62 \div \underline{\quad} = 0.62$$

$$\underline{\quad} \div 100 = 0.62$$

$$\underline{\quad} \div 10 = 6.2$$

$$\underline{\quad} \div 10 = 2.4$$

$$\underline{\quad} \div 10 = 0.24$$

$$\underline{\quad} \div 100 = 0.24$$

100

62

62

24

2.4

24



I can see patterns.

What patterns can Ron see?

